

# HO6 – Frame Corner

FRILO Software GmbH

www.friilo.com

info@friilo.eu

As of 04/12/2015

**HO6 Frame Corner 01/2016 - Item: HO6-Example ( Project: Localization ) - [input ]**

File Edit Options View Window Help

standard

- DIN 1052:1996-A1
- DIN 1052:2004
- DIN 1052:2008
- EN 1995
- DIN EN 1995:2010
- DIN EN 1995:2013
- ÖNORM EN 1995:2010
- ÖNORM EN 1995:2015
- BS EN 1995:2012

system input

- dowelcircle
- dowel/barbolt
- finger joint
- design loadcases
- remarks

Output

- detail output
- Word
- Screen
- Printer
- Print Preview

Projects Input

**material**  
GL20h

**system**  
Alpha= 20.0 degree  
strut hs= 90.0 cm  
bar hr= 80.0 cm  
strut bs= 12.0 cm (2x)  
bar br= 22.0 cm  
eu= 8.5 cm

**internal forces**  
Vd= -24.00 kN  
Nd= -40.00 kN  
Md= -82.00 kNm  
LDC= medium  
des. sit.= permanent

**fastenings**  
 bar dowel  
 dowels of special kind  
dowel

**circle-position**  
rotation = 0.0 degree  
output

**design**  
 1 circle  2 circles  auto. design **Eta = 1,324**

**out. circle**  
radius= 34.5 cm  
max = 17 pcs  
sel = 12 pcs

**inn. circle**  
radius= 20.5 cm  
max = 10 pcs  
sel = 0 pcs

inclination of bar

04.12.2015 15:30



# HO6 – Frame Corner

*Note:* This document describes the **Eurocode-specific application**. Documents containing old standards are available in our documentation archive at [www.frilo.de](http://www.frilo.de) >> Dokumentation >>Manuals>[Archive](#).

## Contents

<b>Application options</b>	<b>4</b>
<b>Basis of calculation</b>	<b>5</b>
Dowel pins and special dowels	5
Dowel loading	5
Transverse tensile stress	6
Shear stress resistance verifications	7
Torsion spring stiffness	7
Verifications with wedge finger joints	8
<b>Definition of the structural system</b>	<b>10</b>
<b>Dowel ring</b>	<b>11</b>
System definition - dowel rings	11
Fasteners - dowel selection	12
Circular arrangement	12
Design	12
<b>Wedge finger joint</b>	<b>13</b>
System definition for wedge finger joints	13
Design	14
<b>Loads / internal design forces</b>	<b>14</b>
<b>Design options</b>	<b>14</b>
<b>Output</b>	<b>15</b>
Legend of output codes	15
<b>Reference literature</b>	<b>17</b>

Further information and descriptions are available in the relevant documentations:

<a href="#">FDC – Basic Operating Instructions</a>	General instructions for the manipulation of the user interface
<a href="#">FDC – Menu items</a>	General description of the typical menu items of Frilo software applications
<a href="#">FDC – Output and printing</a>	Output and printing
<a href="#">FDC - Import and export</a>	Interfaces to other applications (ASCII, RTF, DXF ...)
<a href="#">FCC</a>	Frilo.Control.Center - the easy-to-use administration module for projects and items
<a href="#">FDD</a>	Frilo.Document.Designer - document management based on PDF
<a href="#">Frilo.System.Next</a>	Installation, configuration, network, database

## Application options

The Frame Corner application is suitable for the design of connections in rigid corners of portal frame trusses of laminated timber that are joined with dowel pins or special dowels in circular arrangement or by wedge finger jointing (one or two joints).

The verification of the corner connection resistance requires the specification of the internal forces  $N$ ,  $M$ ,  $Q$  acting on the frame corner. These forces result from an examination of the entire system.

Five load cases maximum can be taken into account. The verifications are carried out at selected critical points or sections.

### Available standards

- EN 1995 (without NA)
- DIN EN 1995-1-1:2010/2013
- ÖNORM EN 1995-1-1:2010/2015
- BS EN 1995:2012

### The former standards

- DIN 1052:1996-A1
- DIN 1052:2004/2008

are still available for selection. (You can find descriptions referring to older standards in our archive at [www.frilo.eu](http://www.frilo.eu) ▶ Service ▶ Documentation ▶ Manuals.)

## Basis of calculation

### Dowel pins and special dowels

The calculation is based on the description in reference [\[1\]](#). The loading of the dowels and the axial force are assumed to be evenly distributed over all dowels. The force applying to the dowels because of the loading by moments is proportional to the distance of the dowel from the centre of gravity of the corner joint. If the dowels are arranged in two circles in accordance with reference [\[3\]](#), the permissible dowel loading may be reduced by 15 % for all dowels. The angles are always determined anti-clockwise.

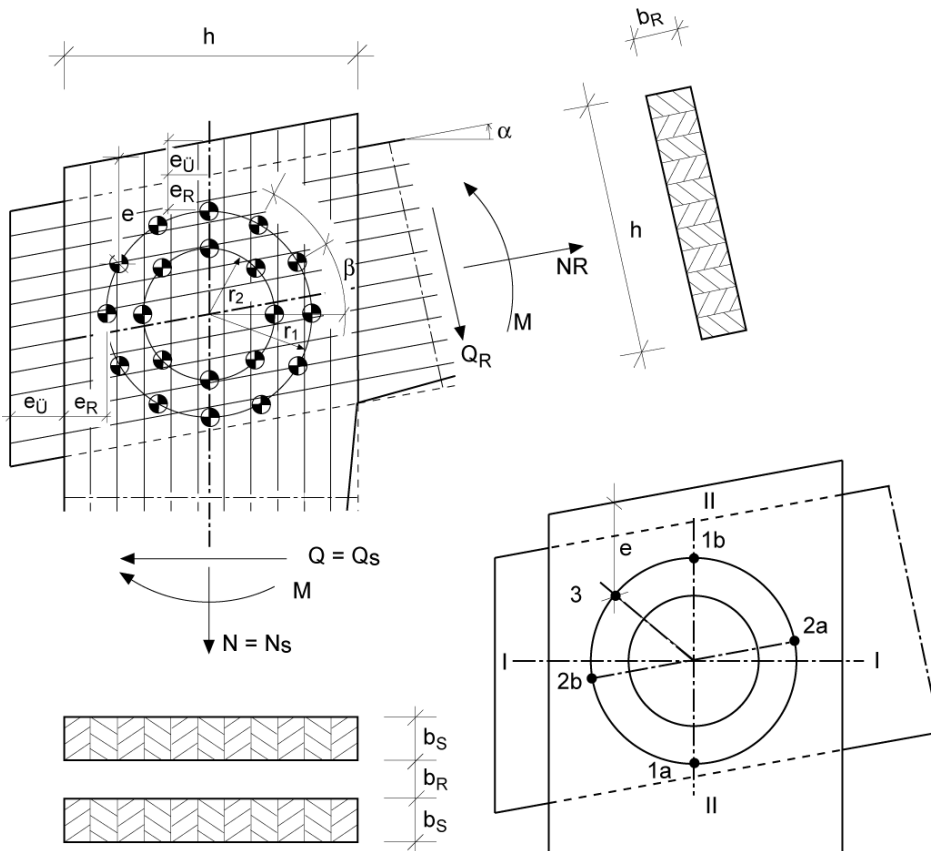

The following verifications are performed:

### Dowel loading

With a single ring of dowels:

$$\text{exist. } F = \sqrt{\left(\frac{Q}{n} - \frac{M \cdot \sin(\beta_i)}{r \cdot n}\right)^2 + \left(\frac{N}{n} + \frac{M \cdot \cos(\beta_i)}{r \cdot n}\right)^2}$$

With two rings of dowels:

$$\text{exist. } F = \sqrt{\left(\frac{Q}{n} - \frac{M \cdot r_i}{l_p} \cdot \sin(\beta_i)\right)^2 + \left(\frac{N}{n} + \frac{M \cdot r_i}{l_p} \cdot \cos(\beta_i)\right)^2}$$

The variables used:

- $n = n_1 + n_2 =$  number of dowels
- $r_i =$  radius of dowel  $i$  (for  $i = 1, 2$ )
- $\beta_i =$  angle coordinate of the dowel  $i$
- $l_p = n_1 \cdot r_1^2 + n_2 \cdot r_2^2$

The dowel loading on the vertical member cross to the grain attains its maximum in point 1a or 1b, depending on the signs of M and Q. On the horizontal member, the maximum loading cross to the grain applies in point 2a or 2b. The angle between the force and the grain is decisive for the permissible dowel loading. It is fixed to 90° in the software. The distance of the dowel pins from the end-grain face should have a length of 6 times the dowel diameter, if no corner reinforcement has been provided for (the default minimum distance is 4·d<sub>d</sub>). All other minimum distances are specified in the standard.

In the calculation, each individual dowel is verified with its dedicated force-fibre angle.

You should ensure in this connection the proper arrangement of the dowels in the ring.

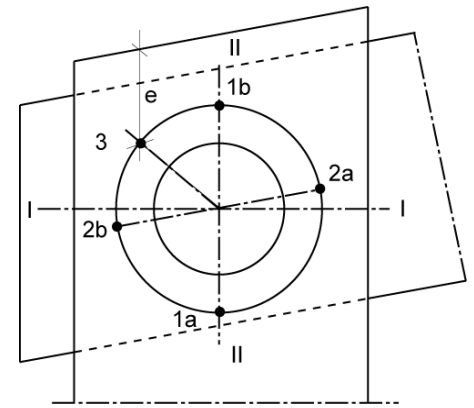

### Transverse tensile stress

You can optionally verify the transversal tensile stress in the upper corner (point 3). According to reference [/3/](#), this verification is in most cases only required if the permissible dowel loading and the minimum distances are not complied with or the shear stress exceeds 0.9 MN/m<sup>2</sup>. The force component of a dowel perpendicular to the grain can produce cracking of the cross section in the corner area. If required, this area must be safeguarded by screw nails or screws. If two dowel rings are defined, corner reinforcement is always recommended to increase the load-bearing capacity.

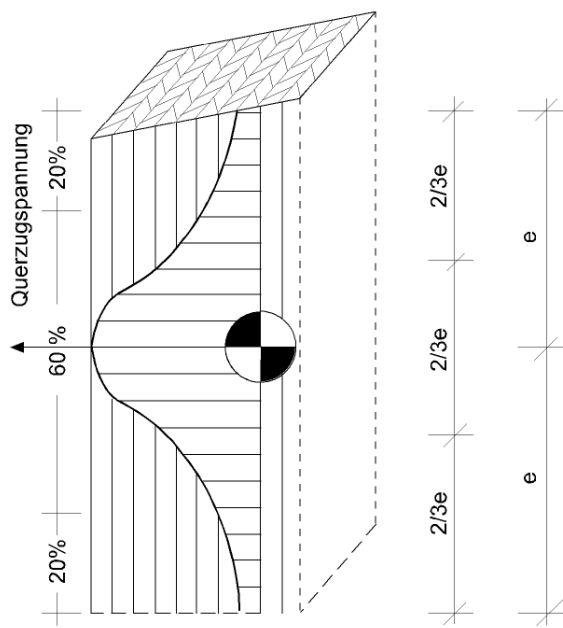

Ill.: Maximum transverse tensile stress as per reference /1/:

$$\text{exist. } \sigma_z = 0,6 \cdot \frac{Q_H}{d \cdot \frac{2}{3} \cdot e}$$

Q<sub>H</sub> = horizontal dowel force

d = timber width

e = distance of dowel to end-grain face

A force component Q<sub>H</sub> acting in direction of the edge is more likely to produce cracking cross to the grain than a force in the opposite direction. Therefore, the force acting towards the edge is assumed

positive. A force action in the opposite direction is assumed negative. Depending on the sign of  $Q_H$ , the verification is based on the following condition:

$$-1 \leq \text{exist.} \frac{\sigma_z}{\text{perm.} \sigma_z} \leq +1$$

The corresponding condition applies to the horizontal member; a positive force acts from the bottom to the top.

Computing is based on the most unfavourable assumption that horizontal loading of a dowel produced by the shear force component acts in the same direction as horizontal loading on that dowel produced by moments. The minimum increase of the distance to the edge  $e$  due to an inclination of the horizontal member is not taken into account.

An inclination angle, a displacement of the dowels in the ring or load portions with opposite signs may produce a situation in which the decisive dowel is not the one with the lowest distance to the edge.

Because all dowels are verified individually, their respective force components are known and a more accurate and economic verification can be performed.

Tests have revealed that frame corners fail in most cases when the shear or transverse tension limit is attained in the corner area. Therefore, Heimeshoff recommends in reference /3/ the design of a corner reinforcement for a force  $N_D = n_1/12 \cdot D_M$  ( $D_M$  = dowel force caused by a moment) if two dowel rings should be installed.

### Shear stress resistance verifications

The maximum shear forces in the horizontal and vertical members occur in section I-I and II-II:

$$\text{Vertical member in section I-I:} \quad Q_{I-I} = Q/2 - M/r/\pi$$

$$\text{Horizontal member in section II-II:} \quad Q_{II-II} = N/2 - M/r/\pi$$

If you have defined two dowel rings, replace the second term by:

$$\frac{M}{\pi} \cdot \frac{n_1 \cdot r_1 + n_2 \cdot r_2}{n_1 \cdot r_1^2 + n_2 \cdot r_2^2}$$

Shear stress:

$$\tau_{Q \text{ I-I}} = 3/2 \cdot Q_{I-I} / A_{I-I}$$

$$\tau_{Q \text{ II-II}} = 3/2 \cdot Q_{II-II} / A_{II-II}$$

Since the shear stress inside the dowel ring is decisive, the properties of the unweakened cross section are used.

$$\frac{\text{exist.} \tau_Q}{\text{perm.} \tau_Q} \leq 1$$

The software uses a permissible  $\tau_Q = 1.2 \text{ MN/m}^2$  in the calculation deviating from the recommendation in reference /3/. In combination with DIN 1052:2008 and EN 1995,  $f_{v,d}$  is used. The stresses and loading are verified for each load case.

### Torsion spring stiffness

The torsion spring stiffness is determined with the help of the expression:

$$K_{m,\text{mean}} = \frac{2}{3} K_{\text{ser}} \cdot I_p$$

taking the displacement module  $K_{\text{ser}}$  into account.

## Verifications with wedge finger joints

The calculation is based on reference /2/. In wedge finger connections with one or two wedge finger joints, the stress distribution with a negative corner moment is as follows:

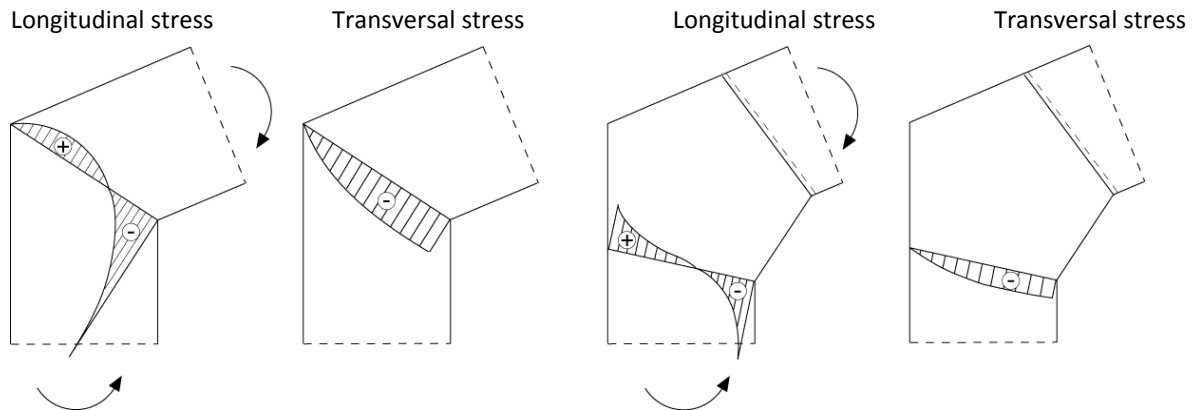

III.: Stress distribution

On typical frames with a negative corner moment, the resistance to the high compressive stresses applying at the inner edge of the corner must be verified.

As a positive corner moment produces transverse tensile stress and the load-bearing behaviour is largely unknown, this type of wedge finger joint should not be used if larger positive corner moments apply. Until clarification of the load bearing, the permissible longitudinal tensile stress will be reduced to 20 % of  $\sigma_D$  as recommended by reference /2/.

The following applies to the stress resistance verifications in the horizontal and vertical members:

$$\text{exist. } \sigma_D(\gamma) = \omega \cdot \frac{N}{A_n} + \frac{\text{perm. } \sigma_{DII}}{\text{perm. } \sigma_B} \cdot \frac{M}{W_n}$$

Because the signs are defined negative if pressure applies and positive if tension applies, the following conditions must be satisfied in the verifications:

$$\text{With pressure: } \text{exist. } \sigma_D(\gamma) = \text{perm. } \sigma_D(\gamma) \text{ MN/m}^2$$

$$\text{With tension: } \text{exist. } \sigma_z(\gamma) = 0,2 \cdot \text{perm. } \sigma_D(\gamma) \text{ MN/m}^2$$

The permissible compressive stress is set to the value applicable for coniferous timber S10 by default.

$\gamma$  is the angle between the force and the grain. N, M are the internal forces, converted by the software, that are referenced to the centre of the wedge finger joint.  $A_n$  and  $W_n$  refer to the decisive net cross section properties at the frame corner perpendicular to the member axis, which are reduced to the 0.8-fold values of the gross cross sectional properties due to the weakening effect of the wedge finger joint.



Calculation of the internal design forces with two wedge finger joints:

$$\text{Joint vertical member: } Q_s = Q, N_s = N, M_s = M - Q \cdot l'$$

$$\begin{aligned} \text{Joint horizontal member: } Q_r &= N \cdot \sin(\gamma) + Q \cdot \cos(\gamma) \\ N_r &= N \cdot \cos(\gamma) - Q \cdot \sin(\gamma) \\ M_r &= M - N \cdot l \cdot \cos(\alpha) + Q \cdot l \cdot \sin(\alpha) \end{aligned}$$

$$\text{with } l' = 0,5 \cdot \left( h + \frac{a}{\tan(\gamma)} \right) \cdot \tan(2 \cdot \gamma) - \tan(\gamma)$$

In the design, the verification as per DIN EN 1995 is implemented as follows:

$$\frac{f_{c,0,d}}{f_{c,\gamma,d}} \cdot \left( \frac{\sigma_{c,0,d}}{k_c \cdot f_{c,0,d}} + \frac{\sigma_{m,d}}{f_{m,d}} \right) \leq 1 \quad \text{with} \quad f_{c,\alpha,d} = \frac{f_{c,0,d}}{\sqrt{\left( \frac{f_{c,0,d}}{2 \cdot f_{c,90,d}} \sin^2 \alpha \right)^2 + \left( \frac{f_{c,0,d}}{2 \cdot f_{v,d}} \sin \alpha \cdot \cos \alpha \right)^2 + \cos^4 \alpha}}$$

For the strength levels  $f_{m,k}$ , always the next lower strength class should be used.

You should estimate the buckling coefficients  $k_c$  for the vertical and horizontal members in accordance with the given conditions and set them manually.

As recommended by reference [/2/](#), a permissible stress of 20 % is considered in the calculation if the corner moments are positive.

## Definition of the structural system

Select first the desired connection:

- [Dowel ring](#)
- [Wedge finger joint](#)

The corresponding definition dialog is displayed.

For the geometry of the system, it is assumed that the grains in the horizontal and vertical members run in parallel to the outer member edges. Slanted interior edges do not affect the calculation in any way. The corner area to be examined is described by a characteristic cross section height  $h$  for the vertical and horizontal members (perpendicular to the member axis). As the cross section dimensions in the frame corner are determined by the connection exclusively, we recommend estimating the actual cross section axes and the location of the centre of rotation as exact as possible.

### Material selection

You can select the sorting class directly.

To enter the usage class and the material coefficients (specific weight  $\gamma$ ), click on the  button.

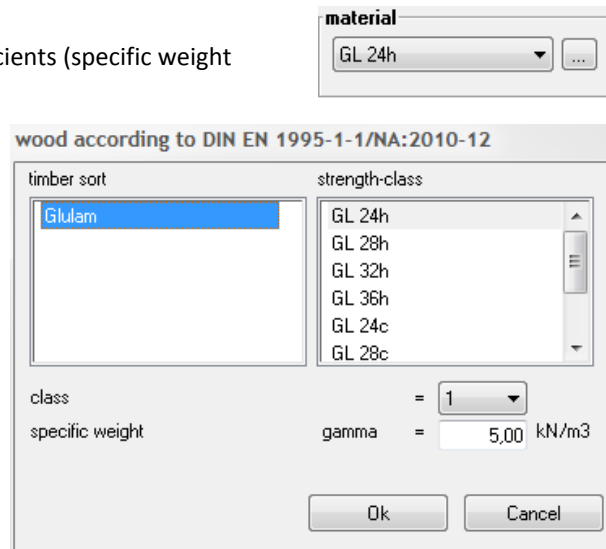

**material**

GL 24h

**wood according to DIN EN 1995-1-1/NA:2010-12**

timber sort	strength-class
Glulam	GL 24h
	GL 28h
	GL 32h
	GL 36h
	GL 24c
	GL 28c

class = 1

specific weight gamma = 5,00 kN/m<sup>3</sup>

Ok Cancel

## Dowel ring

### System definition - dowel rings

Dowel pins should be preferred to special dowels because they are easier to install and can bear higher loading. Dowelled frame corners must be protected against shrinkage cracking if they are installed outdoors or in locations with high climatic variations. This is of particular importance in combination with large dowel rings that require great cross section dimensions.

<b>Alpha</b>	inclination of the horizontal member, angle between the horizontal axis and the member edge
<b>Vertical member hs</b>	height of vertical member
<b>Horizontal member hr</b>	height of horizontal member
<b>Vertical member bs</b>	width of vertical member
<b>Horizontal member</b>	width of horizontal member
<b>eu</b>	existing projection

system	
Alpha=	<input type="text" value="20.0"/> degree
strut hs=	<input type="text" value="80.0"/> cm
bar hr=	<input type="text" value="80.0"/> cm
strut bs=	<input type="text" value="12.0"/> cm (2x)
bar br=	<input type="text" value="22.0"/> cm
eu=	<input type="text" value="8.5"/> cm

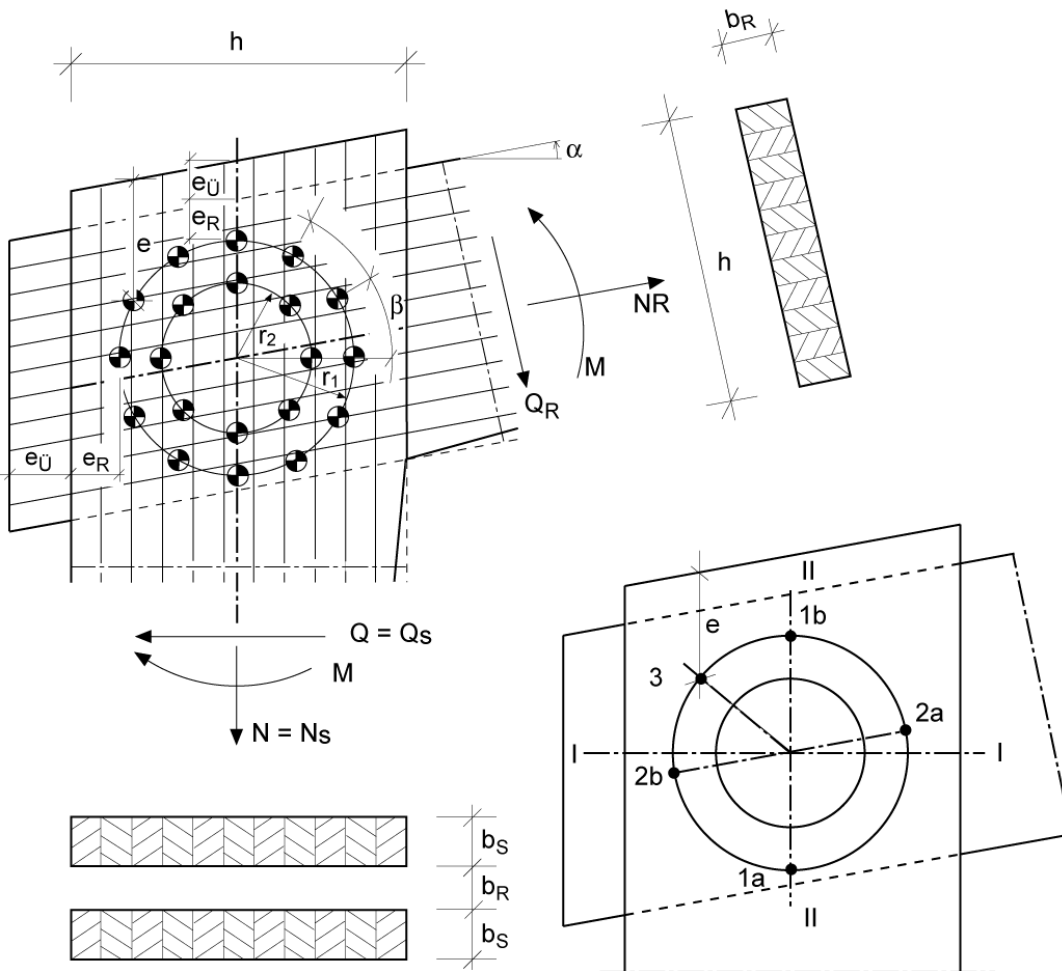

III.: Circular dowel arrangement (dowel rings) on a frame corner

You must define distances for the dowel arrangement.

Projection:  $e_U \geq 0 \text{ cm}$

Distance to the edge:  $e_R = \frac{h_s - 2 \cdot r_1}{2}$

Distance to the edge:  $e_R$  special dowels  $\geq b/2$   
pin dowels  $\geq 3 \cdot d_d$

The distance ( $e_U + e_R$ ) to the grain-end face of the dowels close to the edge must be complied with: dowel pins  $\geq 4 \cdot d_d$  (slanted connection with an angle of  $60^\circ$  approx.) and special dowels  $\geq e_d$ .

If no corner reinforcement is provided for, pin dowels should have a minimum spacing of  $6 \cdot d_d$  in accordance with reference /3/. For the distance  $e$  of the dowel at point 3 to end-grain face, which is decisive for the transverse tension resistance verification, the following applies:

$$e = e_U + e_R + r_1 \cdot (1 - \sin\beta + \cos\beta \cdot \tan\alpha)$$

$\beta$  = angle coordinate of dowel 3 =  $135^\circ + \alpha/2$

## Fasteners - dowel selection

Check either the Dowel pin or Special dowel option and click to the "Dowel" button to display the dialog for the selection of the fastener type.

## Circular arrangement

The rotation angle for the circular arrangement should be defined in the anti-clockwise direction. The specifications are immediately shown on the graphic screen.

## Design

**1 / 2 rings** select two rings only if a solution with a single ring is not appropriate for structural reasons or because of the geometry. The permissible dowel load is reduced when defining two rings.

**Outer ring** the outer ring is defined by its radius and the number of dowels. If the cross section dimensions are given, you can increase the radius by selecting a projection "[eu](#)".

**Max.** indicates the maximum number of fasteners that you can arrange geometrically in the ring.

**Req.** indicates the structurally required number of fasteners to be arranged in the ring.

**Sel.** specification of the (selected) number of dowels in the ring.

**Inner ring** the definition options for the inner ring are enabled when you activate the two rings option.

**Eta** displays the maximum utilization ratio of the dowel and the cross section.

**design**

1 circle  2 circles  auto. design **Eta = 1,232**

**out.circle**

radius= 34,5 cm

max = 17 pcs

sel = 12 pcs

**inn.circle**

radius= 20,5 cm

max = 10 pcs

sel = 0 pcs

## Wedge finger joint

### System definition for wedge finger joints

Double-clicking on the corresponding item in the main menu displays the dialog for the definition of the wedge finger joint. Select the number of joints (1 / 2 joints)

<b>Alpha</b>	inclination of the horizontal member, angle between the horizontal axis and the member edge
<b>h</b>	cross section height of the vertical and horizontal members in the corner area
<b>b</b>	width of the horizontal and vertical members
<b>a</b>	length of the intermediate section (with two joints)
<b>kc,S</b>	buckling coefficient of vertical member
<b>kc,R</b>	buckling coefficient of horizontal member

<b>system</b>	
Alpha=	20,0 degree
h=	80,0 cm
b=	12,0 cm
a=	22,0 cm
kc,S=	1,00
kc,R=	1,00

<b>number joints</b>	
<input type="radio"/>	1 joint
<input checked="" type="radio"/>	2 joints

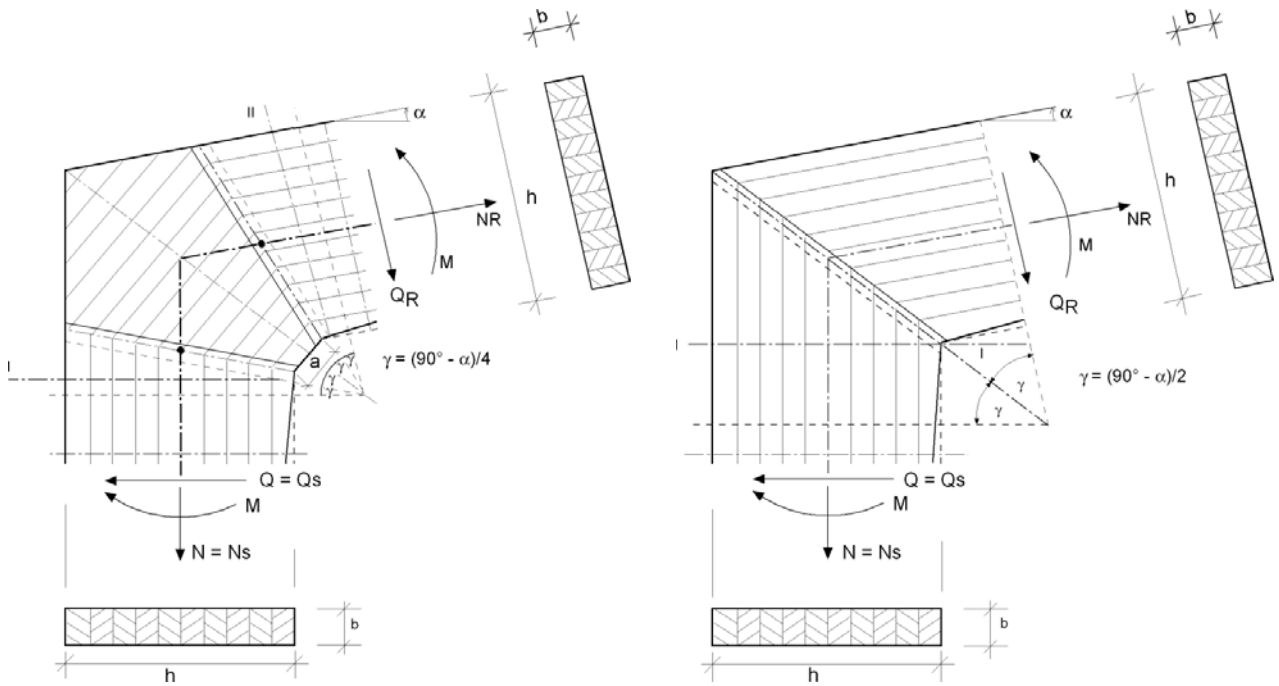

III.: Connection with one or two wedge finger joints.

If an intermediate section was defined, the grain angle is halved. This increases the permissible stresses.

The forces generated through the change of direction in the component are assumed to produce only lateral pressure (this is true with negative corner moments). In the structurally ineffective area of the corner, no bracing should be connected.

The required buckling coefficients for the horizontal and vertical members shall be estimated if no accurate calculation is carried out. The most unfavourable value for buckling in/out of the frame plane shall be taken into account in each case.

## Design

The existing stresses in the lower fibre and the utilisation ratio are displayed for the horizontal and vertical members.

## Loads / internal design forces

Specify the internal design forces

Vd shear force

Nd axial force

Md moment

with the associated class of the load-action period "KLED" in the ultimate limit state.

Des. sit. design situation: you can optionally select the accidental design situation. In this case, the material coefficient  $\gamma_M = 1.0$  is used in the calculation.

$$R_d = R_k \cdot \frac{k_{mod}}{\gamma_M}$$

**internal forces**

Vd= -24,00 kN

Nd= -40,00 kN

Md= -82,00 kNm

LDC medium-te

des. sit. permanent

permanent/transient

accidental

**fastenings**

bar dowel

dowels of special kind

dowel

**circle-position**

rotation = 0,0 degree

## Design load cases

Activating the item "Design LC" in the main menu accesses the load case definition dialog. You can define five load cases maximum.

load input H06

lc-type	Sit	LDC	V [kN]	N [kN]	M [kNm]
1	200	0	-24,00	-40,00	-82,00
	0	permanent/transient			
	1	accidental			

Ok Cancel

## Design options

Activating the "Options" menu item accesses the design options dialog.

For special dowels type C, you can optionally take the load-bearing capacity of the bolt into account.

The verification of the resistance to transverse tensile stress is optionally available for individual dowels.

## Output

The user can launch the output of system data, results and graphical representations on the screen or the printer via the Output menu item in the main menu.

Extensive output the different scopes of the normal and the extensive output are described in the following chapter (legend).

Word If installed on your computer, the text editor MS Word is launched and the output data are transferred. You can edit the data in Word as required.

Screen displays the values in a text window on the screen

Printer starts the output on the printer

Page view (file menu) displays a [Print preview](#).

## Legend of output codes

### Output of the dowel loading

In the standard output, only the decisive dowel is put out for each load case, whereas the extensive output includes all dowels for all load cases.

dowel loading outside								
lc	D.No	$F_{tot,d}$ [kN]	$\beta_{tot}$ [Grad]	$\alpha_S$ [Grad]	$\alpha_R$ [Grad]	$R_{d,c}$ [kN]	$R_{d,b}$ [kN]	$\eta$
1	1	11.613	85.1	4.9	65.1	9.426	0.000	<b>1.232</b>

LC load case number

D.no. dowel number

$F_{tot,d}$  total resultant of the dowel loading

$\beta_{tot}$  associated direction of loading

$\alpha_S$  force-fibre angle of the resulting dowel loading in the vertical member

$\alpha_R$  force-fibre angle of the resulting dowel loading in the horizontal member

$R_{d,c}$  resisting load of the dowel

$R_{d,b}$  resisting load of the bolt, if available (depends on the dowel type)

$\eta$  utilization ratio

### Output of the distances to the edges

In the standard output, only the existing minimum and required maximum distances are put out.

In the extensive output, the existing distances and the minimum values among them are put out for each dowel in the first row.

edge distance to loaded edge							
no	strut		bar		$a_{dub}$ [cm]	$e_S$ [cm]	$e_R$ [cm]
	$a_{90,S}$ [cm]	$a_{0,S}$ [cm]	$a_{90,R}$ [cm]	$a_{0,R}$ [cm]			
<i>italic shown values are the required min. values.</i>							
1	5.5	51.1	51.8		18.1	62.9	88.3
	4.0	9.8	5.1		10.0		
2	69.9	32.7	34.0	83.4	18.1	44.0	83.4

No. dowel number

$a_{90,S}$  distance to the loaded edge perpendicular to the grain in the vertical member

$a_{0,S}$  distance to the loaded edge parallel to the grain in the vertical member

$a_{90,R}$  distance to the loaded edge perpendicular to the grain in the horizontal member

$a_{0,R}$  distance to the loaded edge parallel to the grain in the horizontal member

$a_{Dub}$  spacing of the dowels

$e_S$  distance to the end-grain face in the vertical member

$e_R$  distance to the end-grain face in the horizontal member

### Output of the transverse and longitudinal axial forces

In the extensive output, the transverse and longitudinal axial forces in the dowels are put out in addition.

#### transversal and longitudinal forces in dowels

lc	d.no	dx	dy	Ftot	Beta	FHtot	FVtot	FHM	FVM
1	1	0.34	0.00	11.61	85.1	1.00	11.57	0.00	9.90

LC	load case number
D.no.	dowel number
dx	distance to the ring centre in the horizontal direction
dy	distance to the ring centre in the vertical direction
Ftot	total resultant of the dowel loading
Beta	associated angle of the resultant
FHtot	horizontal force component of the resultant
FVtot	vertical force component of the resultant
FHM	horizontal force component resulting from the moment portion
FVM	vertical force component resulting from the moment portion

Since the axial force and shear force portions are distributed constantly, they are not represented in the table. You can quickly calculate this value from the values shown in the table by subtracting the moments portion from the resultant: e.g.  $FH(Q) = FH_{tot} - FHM$ .

### Output of the transverse tensile stress

In the standard output, only the decisive dowels are put out; in the extensive version, all dowels are put out.

Querzugspannung							
LF	D.Nr	$e_s$ [cm]	$e_R$ [cm]	$\sigma_{t90dS}$ [kN/cm <sup>2</sup> ]	$\sigma_{t90dR}$ [kN/cm <sup>2</sup> ]	$\eta_S$	$\eta_R$
1	2	34.5	75.9	0.0002	0.0060	0.007	<b>0.196</b>
1	6	69.1	27.6	0.0030	0.0002	<b>0.098</b>	0.005

LC	load case number
D.no.	dowel number
$e_s$	distance of the examined dowel to the end-grain edge of the vertical member
$e_R$	distance of the examined dowel to the end-grain edge of the horizontal member
$\sigma_{t90dS}$	transverse tensile stress for 60 % of the dowel loading perpendicular to the grain distributed over 2/3 of the area with $e_s$ in the vertical member
$\sigma_{t90dR}$	transverse tensile stress for 60 % of the dowel loading perpendicular to the grain distributed over 2/3 of the area with $e_s$ in the horizontal member
$\eta_S$	utilization ratio in the vertical member
$\eta_R$	utilization ratio in the horizontal member

### Output of the forces to be borne by the fasteners

lc	$F_{axd,S}$ [kN]	$F_{axd,R}$ [kN]
1	9.90	19.81

LC	load case number
$F_{axd,S}$	tensile force to be borne by the fasteners in the vertical member
$F_{axd,R}$	tensile force to be borne by the fasteners in the horizontal member



## Reference literature

- /1/ Scheer C. und K. Andresen: Ingenieurholzbau. Holzwirtschaftlicher Verlag der Arbeitsgemeinschaft Holz e.V. Düsseldorf 1985
- /2/ Heimeshoff B.: Berechnung von Rahmenecken mit Keilzinkverbindungen. Holzbau - Statik - Aktuell (Folge 1) Mai 1976
- /3/ Heimeshoff B.: Berechnung Rahmenecken mit Dübelanschluß. Holzbau - Statik - Aktuell (Folge 2) Nov. 1977
- /4/ Göggel M.: Bemessung im Holzbau. Wiesbaden; Berlin, Bauverlag, 1981
- /5/ DIN 1052 Ausgabe 1996 - A1
- /6/ Holzbau-Statische Berechnungen Teil 1. Holzwirtschaftlicher Verlag der Arbeitsgemeinschaft Holz e.V., Düsseldorf 1988
- /7/ DIN 1052:2008-12