

ST14 - Welded Beam-to-Column Connection

FRILO Software GmbH

www.friilo.com

info@friilo.com

Version: 1/2013

As of 25/04/2014

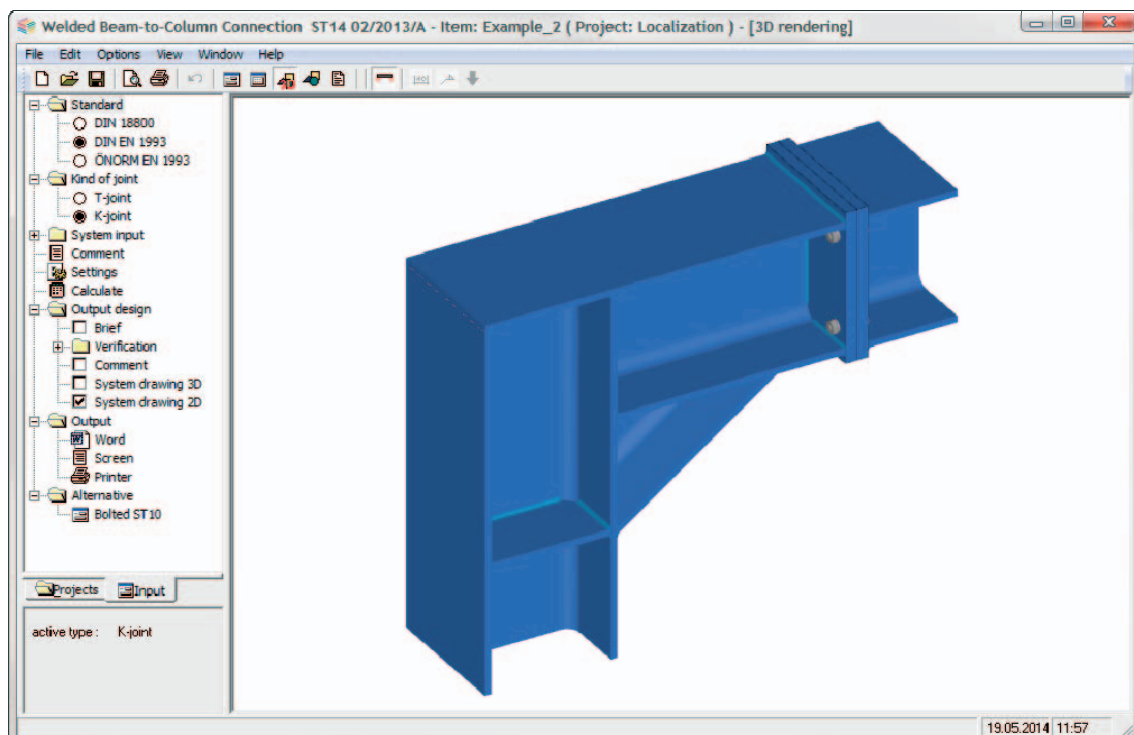

ST14 - Welded Beam-to-Column Connection

Contents

Application options	4
Data entry	5
Definition of the structural system	5
Material	5
Actions	6
Actions - General	7
Geometry	8
Geometry - T-joint	9
Geometry - knee joint	10
Haunch / field joint	11
Stiffeners	13
Shear field	13
Bolt details	14
Calculate / utilization	15
Verification options - settings	15
List of internal forces	16
Table of internal forces	17
Output	18
Output profile	18
Direct transfer to ST10 – Bolted Beam-to-Column Connection	19
Application-specific icons	19
Reference literature	20

Further information and descriptions are available in the relevant documentations:

[FDC – Basic Operating Instructions](#) General instructions for the manipulation of the user interface

[FDC – Menu items](#) General description of the typical menu items of Frilo software applications

[FDC – Output and printing](#) Output and printing

[FDC - Import and export](#) Interfaces to other applications (ASCII, RTF, DXF ...)

[FCC](#) Frilo.Control.Center - the easy-to-use administration module for projects and items

[FDD](#) Frilo.Document.Designer - document management based on PDF

[Frilo.System.Next](#) Installation, configuration, network, database

Application options

ST14 is an application program for the calculation of welded rigid steel frame joints in accordance with DIN 18800, DIN EN 1993 and ÖNORM EN 1993.

Structural system

You can verify typical variants of T-joints and knee joints of double-T profiles:

- T-joint with haunch on one or both sides (joint bracing) and inclined beam
- Knee joint with haunch on one side (joint bracing) and inclined beam
- Knee joint with welded tension plate in addition
- Knee joint with a bolted field joint as per DSTV Guideline (German Steel Construction Association)

In all variants, you can increase the bearing capacity of the shear field by applying transverse stiffeners or a web plate on one side of the web. In addition, you can fit web ribs inside the column.

Loading (actions)

You have to enter the design values of the internal forces N , M_y and V_z . The internal forces must result for the biggest part from dead loads.

Alternating moments can be included.

You can enter multiple combinations of actions via dedicated tables.

Calculation

Subject to verification are the weld seams, the shear fields as well as the transverse stiffeners or the load application points and the joint as per DSTV, if applicable.

The software proposes the required weld seam thickness values, if you activate the corresponding option.

Output

You can document the results in a well-structured, abbreviated or extensive output with the help of a customizable output profile. Optionally, you can generate a three- or two-dimensional graphic representation of the structural system and include additional text notes in the output.

Limitations

The software assumes a braced connection with stiffeners in the column.

Former DSTV Guidelines allow only steel S235 with HV 10.9 bolts flush or projecting on top for the connection. More recent versions of the DSTV Guidelines (2000) permit the use of steel S355 and HV 8.8 in addition. The number of vertical bolt rows is limited to two, however. The field joint is verified only in the load situation where one chord is in tension and the other in compression.

Axial forces are assumed as being low. Former DSTV guidelines require that the relation of I_{web}/I_{total} of the beam does not exceed 0.15.

The verifications of the weld seams are based on the permissible limit weld seam stresses prescribed for S235 respectively S355. For other steels, you must pre-set the factor α_w for the calculation of the limit weld seam stress.

Data entry

Definition of the structural system

First, select the appropriate joint among T-joint and knee joint in the Main menu or the corresponding item in the Edit menu.

Note: A subsequent change of the connection involves the risk of data loss. The software takes over all suitable parameter settings, but when changing from T to knee, for instance, the upper joint bracing will be lost.

After this, define the geometry of the frame joint, its material and the internal forces. If you want to calculate multiple combinations of internal forces in order to compare them, you can enter and handle them via the list of internal forces (accessible via the Actions >> General dialog or the toolbar).

Material

Select the structural steel grade or define a material via the "Free definition" option.



The dialog box shows a dropdown menu for 'material' set to 'structural steel' and a text input field for γ_{M0} set to '1,00'. Below the dropdown is another dropdown menu showing 'S235' and a button with three dots '...'.

To expand the list, click on  or enter user-defined values.

- γ_M the default value of the partial safety factor of the resisting side γ_M is 1.1. You can set it to 1.0 if γ_M is included in the internal forces.
- α_w the α_w factor of the permissible limit weld seam stress as per DIN 18800 P. 1 is set to 0.95 for S235 and to 0.8 for S355. For other steel grades, you must specify it manually.

Free definition

Select the "Free definition" option in the list of steel grades and click subsequently on the  button.

Enter a designation for the material and the characteristic values for the modulus of elasticity and the yield strength f_{yk} .

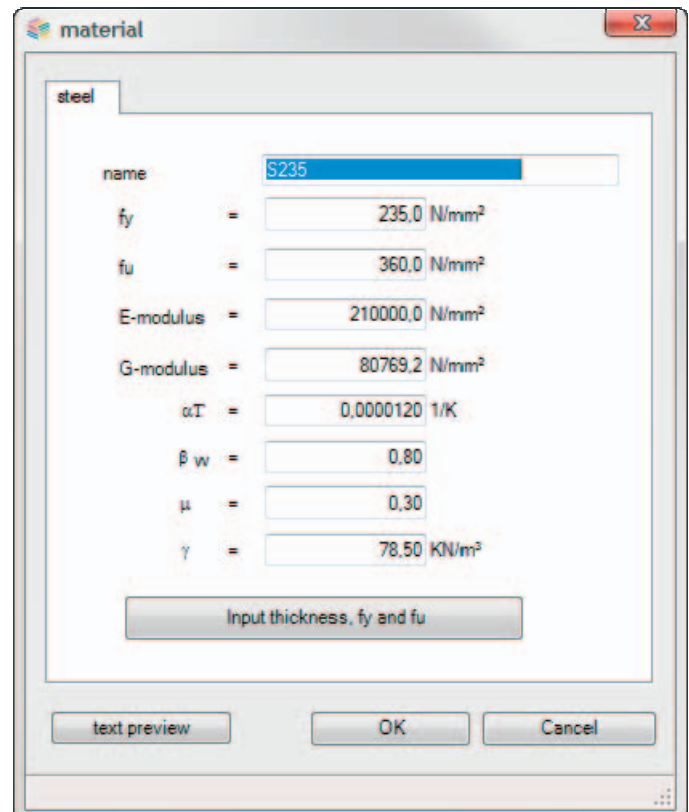

The dialog box is titled 'material' and has a tab labeled 'steel'. It contains the following fields and values:

name	=	S235
f_y	=	235,0 N/mm ²
f_u	=	360,0 N/mm ²
E-modulus	=	210000,0 N/mm ²
G-modulus	=	80769,2 N/mm ²
α_T	=	0,0000120 1/K
β_w	=	0,80
μ	=	0,30
γ	=	78,50 KN/m ³

At the bottom of the dialog box, there is a button labeled 'Input thickness, f_y and f_u '. Below the dialog box are buttons for 'text preview', 'OK', and 'Cancel'.

Actions

The design values of the actions (subscript d) in the in the beam are entered in this section.

Knee joint the internal forces can optionally be applied to the column in the variant "beam above column".

loads (001) [point A]

Nd = -50,00 kN to the list general

Vz = 50,00 kN My = -100,00 kNm

Depending on the pre-condition, internal forces can be assigned to different reference points in the frame joint.

Sign definition: see the chapter [Actions - General](#).

- Nd** axial force transmitted in the direction of the defined centre line (depends on the reference point), positive if it produces tension.
 - Vzd** shear force perpendicular to the defined centre line (depends on the reference point).
 - Myd** moment transmitted about the y-axis; positive, if it produces tension on the bottom side of the section.
- T-joint to verify the shear field, you must enter the internal forces acting in the column in addition → see [Actions - General](#).
- Knee joint to verify a bolted connection as per DSTV, if such a connection was defined, you must enter the associated internal forces in the "Actions - General" dialog.

Actions - General

The design values of the actions (subscript d) must be entered. They can be referenced to the points shown in the illustration below.

T-joint internal forces in the column top apply in point A or E, internal forces in the beam act in one of the points A to D.

Knee joint internal forces applying to the frame joint act in one of the points A to D.

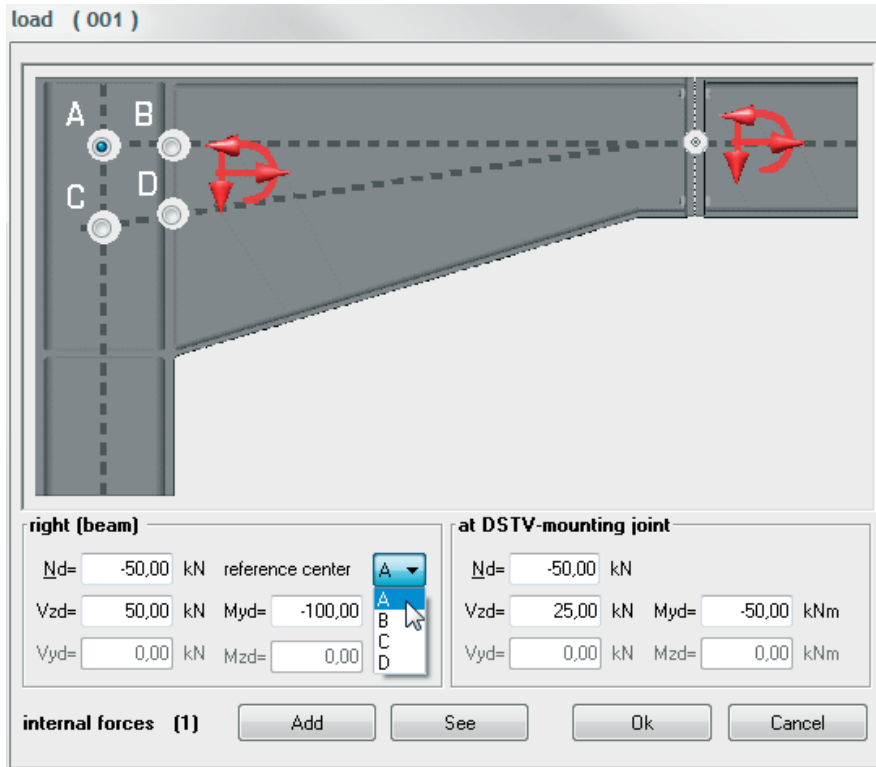

The reference points are defined as follows:

- A intersection of the column centre line with the beam centre line - without haunch
- B intersection of the beam contact face to the column with the beam centre line – without haunch
- C intersection of the column centre line with the beam centre line - with haunch
- D intersection of the beam contact face to the column with the beam centre line – with haunch
- E intersection of the column centre line with the contact face of the shear field on top

Note: "Beam centre line incl. haunch" refers to the angle bisector of the haunch outline.

Knee joint in the "Beam above column" variant, the role of the beam and the column are reversed. The haunch refers to the column in this case. Optionally, the internal forces can refer either to the column or the beam.

Nd axial force transmitted in the direction of the defined centre line (depends on the reference point), positive if it produces tension.

Vzd shear force perpendicular to the defined centre line (depends on the reference point).

Myd moment transmitted about y.

Sign convention: see the illustration in the "Actions - General" dialog showing the symbols of the positive internal forces.

List of internal forces

In the lower area of the dialog, the current number of the given combinations of internal forces is indicated in brackets.

Click on the "Add" button to insert the currently defined internal force immediately into the list.

To perform any kind of operations referring to internal forces (calculate, search maximum value, delete), you can access the list via the "View" button.

Geometry

The buttons "Column section" and "Beam section" allow you to access the dialog for the selection or definition of the corresponding cross section.

Selecting/editing a cross section

You can define cross sections by specifying their dimensions or by selecting them from a list of standard steel shapes.

Available are double-T sections as per DIN and a series of special double-T sections make ARBED.

See also the document [Selecting/Defining Cross Sections](#)

geometry

HE300A

HE300A

beam above column beam incline = 0,0 °

corner stiffening with flange / joint

tension plate

lz= 0,0 mm lz= 0,0 mm

bz= 0,0 mm a,web = 3,0 mm

weld seam beam-column

a,fl.= 4,0 mm a,web = 4,0 mm

stiffening

no strengthening

Select/change the form of cross-section

F3: Goto tree

- 1 - F+L cross section database
 - I
 - IPE
 - HE-A
 - HE-B
 - HE-M
 - ARBED
 - 3 - Dimensions steel
 - 1 - Double-T

Dimensions [mm]

Name: I 290 (sd)

Height h = 290,0

Width b = 300,0

Web s = 8,5

Flange t = 14,0

Radius r = 27,0

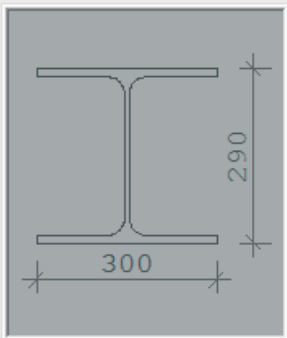

Results [cm4/cm2/cm3]

Iy = 18263,50	A = 112,53	Wyt = 1259,55
Iz = 6309,56	Aqy = 70,00	Wyb = 1259,55
Iyz = 0,00	Aqz = 24,54	Wzl = 420,64
It = 85,57	ATy = 55,11	Wzr = 420,64
	ATz = 22,45	Wt = 61,12

Geometry - T-joint

Beam inclination β angle between the centre line of the beam section and the horizontal line in degrees.

Haunches top/bottom accesses the dialog for the definition of haunches or joint braces. A haunch can be defined with a cranked chord or, in addition, with a continuous chord in the beam in the sense of a joint bracing. You can define additional stiffeners in the beam member at the chord end to ensure resistance against deflection forces.

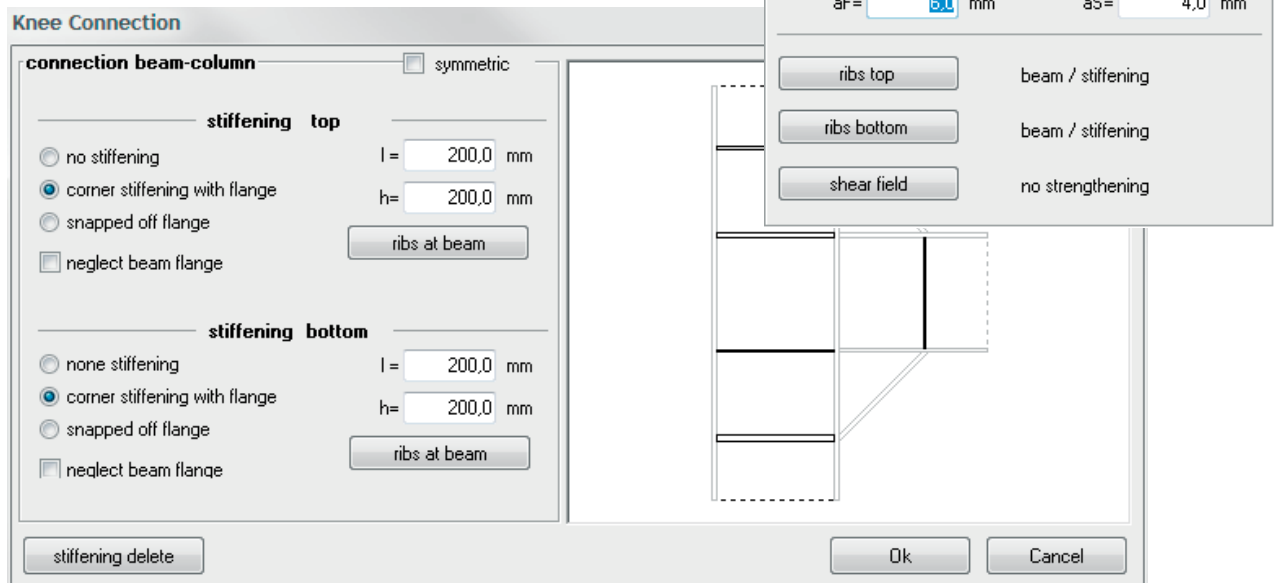

For "symmetrical" versions, the data entry fields for the bottom haunch are disabled.

Weld seam thickness specifications

aF thickness of the weld seam at the chords of the beam

aS thickness of the weld seam in the web area of the beam

Note: Depending on your settings, the data entry fields for aF and aS could be disabled – for automatic design, the weld seam thickness values are set by the software.

Stiffeners on top column bracing by rib stiffeners at the upper beam flange → see the chapter [Stiffeners](#).

Stiffeners on top column bracing by rib stiffeners at the lower beam flange → see the chapter [Stiffeners](#).

Note: A braced connection is assumed.

Shear field bracing of the shear field → see the chapter [Shear field](#).

Utilization

When you activate the 'Calculate' option in the Main menu or the Edit menu, the various utilizations η are calculated for the structural system in the current state. This might be required after changes of the defined system or the definition of a new system.

Areas where $\eta > 1$ are colour marked in the system graph.

Geometry - knee joint

- Beam inclination** angle between the centre line of the beam section and the horizontal line in degrees.
- Beam over column** select this option if the beam should run above the column. In this case, the relation between the haunch and the member is inverted. The changed reference points of the internal forces shall be considered as well. The latters can optionally apply either to the beam or to the column.
- Haunch/field joint** accesses the [dialog](#) for the definition of a haunch or a field joint as a screwed connection as per DSTV (German Steel Construction Association). In the current software version, the field joint option is not available for the "Beam-over-column" connection.
- Tension plate** activate this option to provide a connection with a bolted or welded tension plate. The required data-entry fields are enabled, when you activate this option. Otherwise, the top chord runs over the connected section and is welded to the web of the latter (a,web).

The screenshot shows a 'geometry' dialog box with the following fields and options:

- column section:** HE 300A
- beam section:** HE 300A
- beam above column:** beam incline = 0,0 °
- haunch/mounting j.:** corner stiffening with flange / joint
- tension plate:**
 - lz = 0,0 mm
 - bz = 0,0 mm
 - tz = 0,0 mm
 - a,web = 3,0 mm
- weld seam beam-column:**
 - a,fl. = 4,0 mm
 - a,web = 4,0 mm
- ribs:** stiffening
- shear field:** no strengthening

- lz** length of the welded-on tension plate
- bz** width of the welded-on tension plate (max. width it that of the section)
- tz** thickness of the welded-on tension plate
- a,web** thickness of the weld seam on the web of the connected steel section
- a,chord** thickness of the weld seam on the chord along the steel section with the welded-on tension plate.

Beam-to-column connection

- a,chords** thickness of the weld seams at the chords of the beam
- a,web** thickness of the weld seam in the web area of the beam
- Note:* In the beam-over-column variant, the weld seams refer to the chords and the web of the column.

Note: Depending on your settings, the data-entry fields for a,chords and a,web could be disabled. In automatic design, the weld seam thicknesses are set be the software.

- Stiffeners** this button accesses the dialog for the definition of column braces by rib stiffeners at the lower beam flange.
- Note:* a braced connection is assumed.
- In the beam-over-column variant, a beam bracing at the right column flange is assumed in this case.

- Shear field** bracing of the shear field

Haunch / field joint

A haunch can be defined with a cranked chord or, in addition, with a continuous chord in the sense of a joint bracing.

You can define additional stiffeners at the chord end to ensure resistance against deflection forces. If a field joint is immediately at the chord end, no stiffeners are defined there. The deflection forces are borne by the end plate in this case. You should observe the constructive minimum distance of such a stiffener from the field joint. Otherwise, it may happen, that the software deletes the stiffener automatically after checking the geometry!

Knee Connection

stiffening bottom

none stiffening
 corner stiffening with flange
 snapped off flange
 neglect beam flange

l = 350,0 mm
 h = 250,0 mm

Mounting joint EN 1993

analysis : (Components Method)

connection model : flush

weld seam

aF = 2,0 mm aS = 2,0 mm

bolt geometry M 16 · 10.9 HR

size = M 16 >> dL = 17,0 mm

a1 = 0,0 mm a2 = 45,0 mm

w3 = 35,0 mm w2 = 0,0 mm

ep = 500,0 mm
 tp = 25,0 mm
 bp = 300,0 mm
 ExP = 20,0 mm
 hp = 330,0 mm

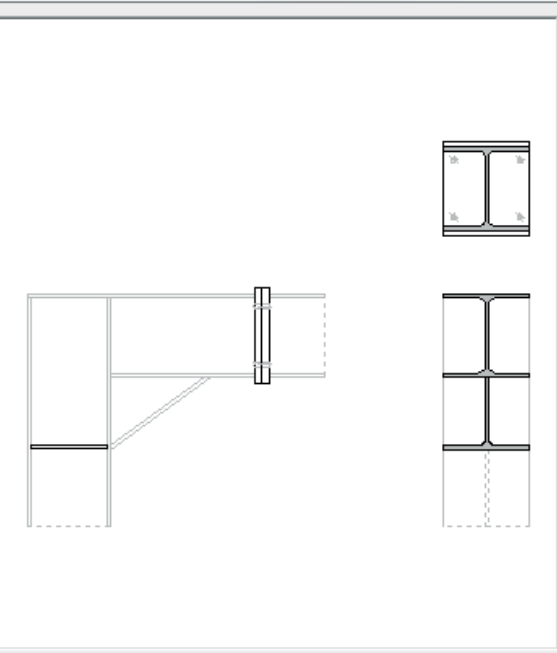

Field joint as per EN 1993 or DSTV

Activate this option to define a knee joint variant with a screwed field joint.

Calculation method

EN 1993

In accordance with the component method. Various calculation options are available in the "Settings" menu.

→ See also [Steel connections – Component method.pdf](#)

DSTV

- In accordance with the former DSTV Guidelines (1984) with S253, bolts HV 10.9 and two or four vertical bolt rows

- In accordance with the more recent DSTV Guidelines (2000) with S235 or S355, bolts HV 8.8 or 10.9 and two vertical bolt rows exclusively. The calculation is based on the simplified method without consideration of the bracing effect of the beam web in the verification of the end plate in bending (EPB).

Flush

end plate flush to the surface or projecting on top.

Four rows

only in combination with the DSTV Guidelines 1984: selection between two or four vertical bolt rows.

ep	distance of the end plate (outer edge of beam to beam splice in length direction). ep cannot be smaller than the (bracing) haunch length.
tp	thickness of the end plate.
bp	width of the end plate.
pp	projection of the end plate on bottom, in combination with the "flush" connection type also on top. pp can also be negative, max. negative value is equal to the thickness of the chord.
hp	height of the end plate; only enabled, if the "projecting" variant was selected.
aF	weld seam thickness at the flanges.
aS	weld seam thickness in the web area.

Note: Depending on your settings, the data-entry fields for "a,chords" and "a,web" may be disabled. In automatic design, the weld seam thickness values are set by the software.

Bolts

Size select the desired bolt size from the list. After you have made your selection, the software proposes a new bolt pattern. In addition, an end plate thickness appropriate for the bolt diameter is proposed, if the calculation is done in accordance with the old DSTV Guidelines.



accesses the definition dialog for the bolt details.

dL hole diameter, depends on the selected bolt type and size.

Bolt spacing in the direction of the beam web

a1 distance of the bolt in the projection to the outer edge of the beam, only enabled if a projecting end plate was defined.

a2 distance of the inner bolt to the outer edge of the beam.

Bolt spacing in the direction of the beam chords

w2 distance of the bolts to the edges.

w3 inner spacing of the bolts on an end plate with four rows.

Each value that you enter is checked for plausibility in regard to the following conditions:

- The permissible minimum bolt spacing must be complied with.
- The total of all bolt distances must be equal to the corresponding plate dimension.
- When defining dL, an internal hole clearance of 0.3 to 2.0 mm for raw bolts and of 0.0 to 0.3 mm for fit bolts should be considered.

Stiffeners

The illustration shows the stiffener dimensions as they are used in the software, t = stiffener thickness. A short description of each data-entry fields is displayed in the status line (on bottom left).

Continuous stiffener

when you check this option, a three-sided stiffener connection is generated, i. e. the stiffener length h is equal to the clear distance of the flanges.

Take over flange thickness

check this option if the stiffener thickness t should be matched to the flange thickness of the connected section.

Stiffener width b

must not exceed the width of the corresponding flange of the section.

Delete stiffener

deletes the dimensions of the current stiffener. Attention: depending on the prerequisites of the verification, the software adds stiffener parameters automatically!

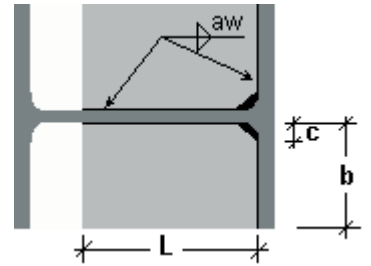

Shear field

Select the corresponding option to reinforce the shear field either with a web plate on one side or diagonal stiffeners on both sides.

shear field input

web plate stiffening

thickness $t =$ mm

weld $aw =$ mm

diagonal stiff. double-s.

thickness $t =$ mm

width $b =$ mm

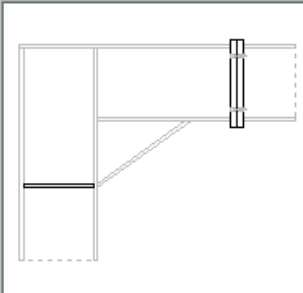

Web reinforcing plate

Thickness t thickness of the web plate

Weld seam aw thickness of weld seam at the web plate

Diagonal bracing on both sides

Thickness t thickness of the stiffener

Width b width of a diagonal stiffener (analogous to the rib stiffener)

To delete a bracing, just untick the corresponding checkbox.

Bolt details

► Haunch/field joint ► Bolt geometry 

The bolt sizes M12 to M36 are available for selection in the strength classes 4.6 to 10.9. You can distinguish between raw bolts and fit bolts.

An internal hole clearance of 0.3 to 2.0 mm for raw bolts and of 0.0 to 0.3 mm for fit bolts can be defined.

You can select whether the joints of a connection shall all be assumed in the bolt shafts or the bolt threads.

In the joint as per DSTV, only pre-loaded bolts are used. The older DSTV Guidelines (1984) only permit HV 10.9 whereas the more recent DSTV Guidelines (2000) allow HV 8.8 in addition.

After having entered the bolt type, the hole diameter is set to the regular hole diameter of the corresponding bolt size. It can be edited and adjusted within the permitted range in the dialog associated to the bolt pattern.

The regular hole diameter of M16, for instance, is 17 mm for raw bolts (internal hole clearance of 1.0 mm) and 17 mm for fit bolts (internal hole clearance of 0.0 mm).

Friction-grip joints are not available.

bolt:

size	strenght
M 12	8.8
M 16	10.9
M 20	
M 22	
M 24	
M 27	
M 30	
M 36	

black bolt
 fit bolt

shank in shear joint
 thread in shear joint

planed pre-stressed
 slide fix connected

Ok Cancel

Calculate / utilization

When you activate the 'Calculate' option in the Main menu or the Edit menu, the various utilizations η are calculated for structural system in the current state. This might be required after changes of the defined system or the definition of a new system. Areas where $\eta > 1$ are colour marked in the system graph.

utilisation ratio		
η	w.-seam =	0,56 weld seam, column
η	tens. plate =	2,24 weld seam from N+M
η	shear field =	0,28
η	ribs =	0,39 Stiffeners required!
η	mounting j. =	1,00 weld seam from N+M

Verification options - settings

To adjust the verification parameters, click on the "Settings" item in the Main menu.

Any changes to the settings in this dialog have an immediate effect on the defined frame joint. When you set up a new item, the software goes back to the default settings, however. In order to set user-defined values as defaults, activate the button "As default".

Propose req. minimum thickness of weld seams

Set this option if the software shall propose the thickness of all weld seams automatically. In this case, all data-entry fields referring to the thickness of weld seams are disabled and filled automatically with the appropriate values after each calculation run. The lower limit for the weld seam thickness is 2 mm.

Check the constructive limits of the weld seam thickness

Only available in combination with the previous option. When you tick this option, the software checks the proposed weld seam thickness values against the constructive weld seam limits and the thickness of the connected components.

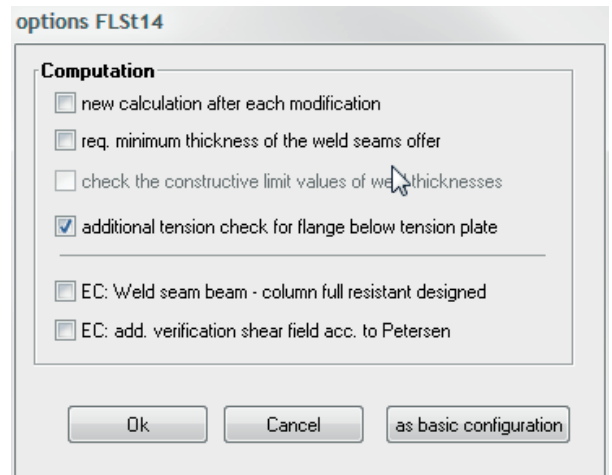

options FLSt14

Computation

- new calculation after each modification
- req. minimum thickness of the weld seams offer
- check the constructive limit values of weld thicknesses
- additional tension check for flange below tension plate

- EC: Weld seam beam - column full resistant designed
- EC: add. verification shear field acc. to Petersen

Ok Cancel as basic configuration

List of internal forces

The list of internal forces allows you to handle any number of combinations of internal forces for the defined structural system in a table.



Click on the icon associated to the list of internal forces or the "Display" button in the [Actions - General](#) dialog. 

Sort

By clicking on the column title, you can sort each column in ascending or descending order.

Apply criteria to the listing

The options below the table allow you to set filters for the rows to be displayed.

The following options are available to filter the entries shown in the list:

- all combinations of internal forces
- all combinations of internal forces with a utilization of more than 100 %
- all combinations of internal forces with a maximum utilization between user-defined limits (in per cent). Maximum utilization in this context means the maximum loading rate from all verifications. To display all sections with a utilization rate greater than the specified lower limit, enter 0.0 for the upper limit.

Delete

Clicking on the "Delete" button deletes the currently selected combinations of internal forces.

Pressing the Shift or Ctrl key while selecting rows allows you to select several combinations of internal forces at a time.

Output

Click on the "Output" button to display the results of the selected combinations of internal forces on the screen. You can use the multi-selection feature to group the sections to be put out.

If you make no further selections, the combination of internal forces in the currently active (high-lighted) row is put out - not to be confused with the combination of internal forces entered in system definition section!

The number(s) of the combination(s) of internal forces is/are added to the output.

Edit

Click on the "Edit" button to access the dialog of the table of internal forces. You can add new combinations of internal forces or edit the existing ones.

Calculation

Activating the "Calculate" option launches the recalculation for all cross sections.

Transfer to structural system

Double-click on a combination of internal forces in the table or activate the "Add to the system" button to take over the selected internal forces in the definition dialog.

Table of internal forces

In this dialog, you can edit the defined combinations of internal forces in the table and add additional ones.

The available table columns (internal forces) depend on the defined structural system.

Explanations of the parameters to define are given in the "[Actions - General](#)" dialog of the T-joint and the knee joint.

Note: Some data entry fields offer selection lists. Click on to expand the corresponding list.

number internal force combination (2)										
	Component	Point	Nd	Myd	Vzd	Component	Point	Nd	Myd	Vzd
1	2: Beam	A	-50,00	-100,00	50,00	3: DSTV	A	-50,00	-50,00	25,00
2	2: Beam	A				3: DSTV	A	-50,00	-50,00	25,00
3		B								
4		C								
		D								

Output

Output of the system data, results and graphical representations on the screen or the printer.

The Output item in the Main menu allows you to start the output on a printer or the screen.

Output profile	the dialog offers comprehensive options for the control of the output scope.
Word	the output data are transferred to the text editor MS Word provided that it is installed on the respective computer. You can edit and format the output data in MS Word.
Screen	displays the values in a text window on the screen
Printer	starts the output on the printer

Output profile

The output profile allows you to define the scope and contents of data to be put out. Only the activated options are considered in the output scope. Depending on the context of the currently active connection variant, particular options might be disabled.

Summary print	option to include or exclude intermediate results from the output (uncheck the option to obtain intermediate results).
---------------	--

Verifications

Shear field	output of the shear field resistance verifications.
Stiffeners	output of the stiffener resistance verifications as well as the verifications concerning the load application.
Tension plate	output of the verifications in the tension plate, if applicable.
Bracing	output of the verifications in the (haunch) bracing area as well as of the verifications in the chords due to partial internal forces.
Field joint	output of the verification of a DSTV joint, if applicable.
Serviceability	only in combination with a field joint in accordance with the older DSTV Guidelines.

Item text	comments on the system.
System graph 2d	two-dimensional representation of the frame joint with details (dimensions and/or legends).
System graph 3d	three-dimensional front view of the frame joint in isometric mode.

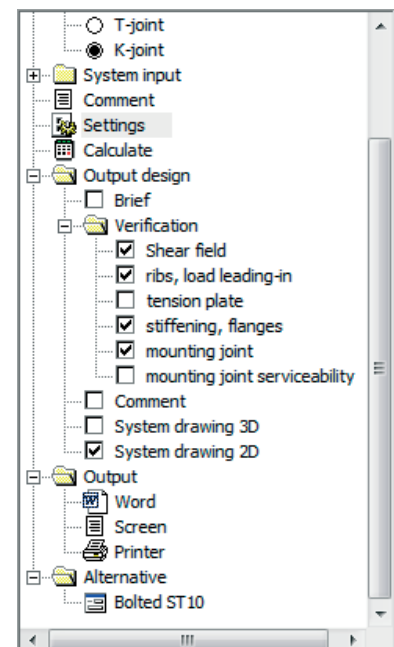

Direct transfer to ST10 – Bolted Beam-to-Column Connection





You can transfer the defined structural system to the ST10 application for further processing as a bolted connection. The internal forces combination of the system definition is transferred and converted to the reference point A, if required.

To do this, activate the corresponding menu item in the Main menu (sub-item of "Alternative") or the option "Bolted ST10" in the "Edit" menu.

Application-specific icons

In addition to the standard icons, each application program offers application-specific functions via additional icons and tool bars.



-  List of internal forces
-  Connection in 3-d
-  Hide/display dimension lines
-  Hide/display legends
-  Hide/display internal forces

Reference literature

- [1] DIN 18800, November 1990, Part 1.
- [2] PETERSEN, CHR.: *Stahlbau*. 3rd Edition. Vieweg & Sohn, Braunschweig , Wiesbaden 1993.
- [3] Typisierte Verbindungen im Stahlhochbau, 2nd Edition. Deutscher Stahlbau - Verband DSTV in Zusammenarbeit mit dem Deutschen Ausschuss für Stahlbau (DASt). Stahlbau-Verlagsgesellschaft mbH, Köln 1984.
- [4] G. SEDLACEK; K. WEYNAND; S. OERDER: [3] Typisierte Verbindungen im Stahlhochbau, 1st Edition. Deutscher Stahlbau-Verband DSTV, Stahlbau-Verlagsgesellschaft mbH, Köln 2000.
- [5] J. Lindner, J. Scheer, H. Schmidt (Hrsg.): *Stahlbauten. Erläuterungen zu DIN 18800 Teil 1 bis Teil 4 (Beuth Kommentare)*. Beuth, Berlin, Köln; Ernst & Sohn, Berlin 1993.
- [6] E. KAHLMEYER: *Bemessung und Konstruktion Träger - Stützen - Verbindungen*. 1st Edition. Werner, Düsseldorf 1993.
- [7] R.KINDMANN; M.STRACKE: *Verbindungen im Stahl- und Verbundbau*. 1st Edition. Ernst & Sohn, Berlin 2003.
- [8] DIN EN 1993-1