

Cantilevered Retaining Wall WSM+

Contents

Application options	2
Basis of calculation	4
Lateral earth pressure	4
Lateral earth pressure on plane of rupture	5
Earth pressure acting on the wall	6
Earth resistance	7
Other actions	8
Weight of soil	8
Water pressure	8
Ground-surface loads	9
Component loads	10
Verification of the external stability	11
Overturning in accordance with DIN 1054	11
Sliding	11
Ground failure	13
Simplified verification in typical cases (only with DIN)	13
Embankment failure	14
Gapping joint/overturning as per ÖNORM B 4435-2	16
Settlement calculation	16
Verification of the internal stability	17
Wall design	17
Foundation design	18
Data entry	20
Basic parameters	20
Structural system	21
Cantilevered retaining wall	21
Soil	21
Ground surface / groundwater	22
Loading	23
Soil loads	23
Terrain loads on valley-side embankment	23
Member loads	24
Design	25
Lateral earth pressure	25
Cantilever wall	27
Geotechnical design	28
Results	30
Symbols for the result graphs	31
Output	32
Reference literature	33

Application options

The software allows the verification of the structural safety and the design of cantilevered retaining walls of reinforced concrete. The retaining wall may have a toe and a heel. The top face of the heel and the wall front and rear surfaces can be slanted. The base can be inclined.

The ground surface behind the wall can be horizontal or sloped upwards with a straight or polygonal profile. A downwards slope (negative slope) is also possible.

The ground can consist of any number of horizontally limited soil layers. Stagnant groundwater can be considered as well as different lateral earth pressure situations (e.g. earth pressure due to compaction, increased active earth pressure).

Available standards

You can base the calculation of the reinforcement either on

- DIN EN 1992-1-1:2015
- ÖNORM EN 1992-1-1:2011/2018
- PN EN 1992-1-1:2010

Still available:

DIN 1045-1, DIN 1045:1988 and ÖNorm B 4700

Geotechnical standards

The geotechnical verifications can be based on:

- DIN EN 1997-1 or DIN 1054 in the persistent design situation
- ÖNORM EN 1997-1 in the design situation DS-1 in combination with any consequence class.
- PN EN 1997-1

Loads

- Area load, line load and moment acting on the wall crown and the toe
- Horizontal force applying at a freely selectable height to the wall and the toe
- Area load on the ground surface, optionally applying distant to the wall
- Strip load, line load and block load applying at a freely selectable position on the ground surface or inside the soil

Other actions

Stagnant groundwater can be considered.

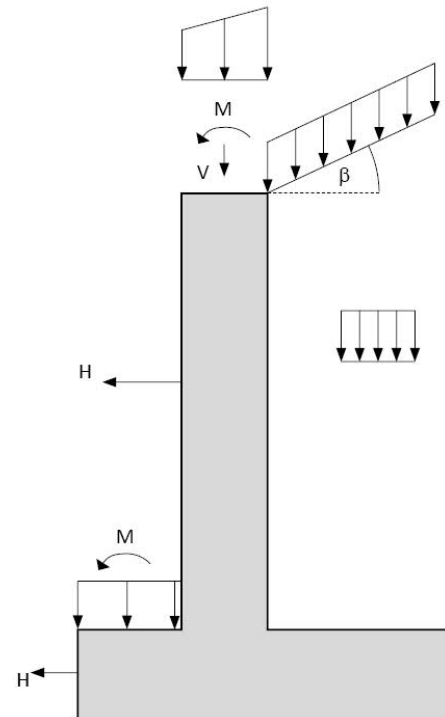

Results

- Overview of the decisive load case combinations and the verification results
- Output of the earth pressure behaviour on the wall and the plane of rupture as a graphic and in the form of tables
- Water pressure curve
- Verification of the overturning stability
- Verifications of the ground failure resistance and the sliding stability or
- Simplified verification in normal cases as per DIN 1054 6.10 (not with ÖNORM)
- Embankment failure analysis including sliding circle representation
- Analysis of the gapping joint in the first and second core range (in combination with ÖNORM this verification replaces the overturning stability verification according to DIN 1054)
- Additional features for verifications in accordance with DIN: the software checks whether verifications of the stability against incompatible torsion/displacement are required. These verifications are not performed, however.
- Output of the settlement and twisting
- Base pressure gradient for the design of the heel and toe on bending and shear force
- Reinforced concrete design in the ULS ¹⁾ of the wall on a freely selectable number of points (bending and shear force). Output of the required reinforcement.
- Reinforced concrete design in the ULS of the toe and heel at their contact surfaces (bending and shear force). Output of the required reinforcement.

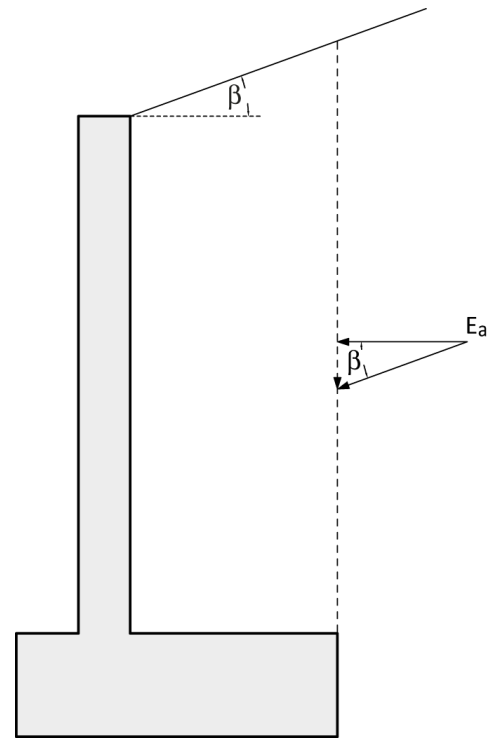

Earth pressure component on the vertical joint of rupture at the end of the heel

The geotechnical verifications are based on the persistent design situation.

¹⁾ ULS: ultimate limit state

Basis of calculation

WSM+ performs verifications of the internal and external stability of an angular retaining wall in the persistent design situation. Well-drained soil (calculation with the effective shear parameters $\phi = \phi'$, $c = c'$) and stagnant groundwater are assumed.

Lateral earth pressure

Lateral earth pressure is calculated in accordance with DIN 4085 or EAB and the 'Grundbautaschenbuch'. The minimum earth pressure is determined in accordance with EAB ($\phi_{\text{equiv}} = 40^\circ$, comparison of the resultant forces, earth pressure generated by area loads with a characteristic friction angle).

The software allows the selection either of a perpendicular plane of rupture at the heel end or of an inclined plane of rupture starting at the heel end (first plane of rupture), which hits the ground surface or the wall depending on the length of the heel. In general, the method based on an inclined plane of rupture (also: method based on two plane of ruptures) is more cost-efficient.

Where discontinuous slopes are concerned, the earth pressure is considered in accordance with Jenne:

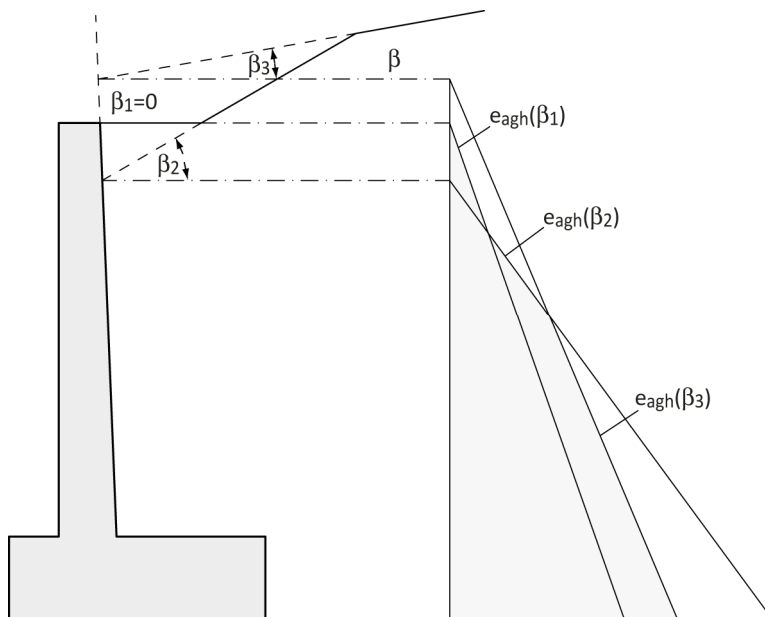

The earth pressure is always applied as a single action that has either a favourable or an unfavourable effect. This means that you cannot consider the vertical components separately from the horizontal ones. The earth pressure resulting from the self-weight is considered separately from the soil self-weight, however, and is combined correspondingly.

Lateral earth pressure on plane of rupture

The earth pressure acting on the plane of rupture has an influence on the verifications of the external stability (geotechnical analysis) as well as on the design of the foundation.

To determine the earth pressure acting on the inclined plane of rupture in combination with multiple earth layers, the inclination angle α_{max} of the plane of rupture is to be determined for each soil layer individually. The result of this method is a plane of rupture with linear sections and kinks at their joints.

$$\alpha_{Max} = \vartheta_{ag} - \varphi$$

with:

$$\vartheta_{ag} \text{ for } \alpha = 0^\circ \text{ and } \delta_a = \beta$$

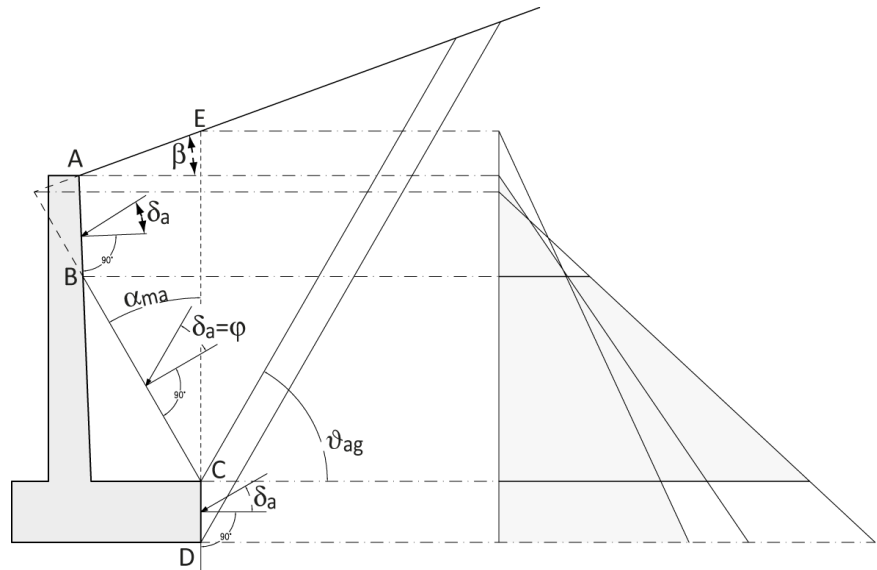

To simplify the calculation in combination with perpendicular planes of rupture, the earth pressure is assumed applying to the plane of rupture at an angle that is equal to the inclination angle of the ground surface. Where discontinuous slopes are concerned, the inclinations of the slope sections that belong to the sliding mass at an angle of base friction of $\vartheta = 60^\circ$ are averaged. This mean value is used to calculate the earth pressure. Slope sections of which only a part belongs to the sliding mass are only considered with that part.

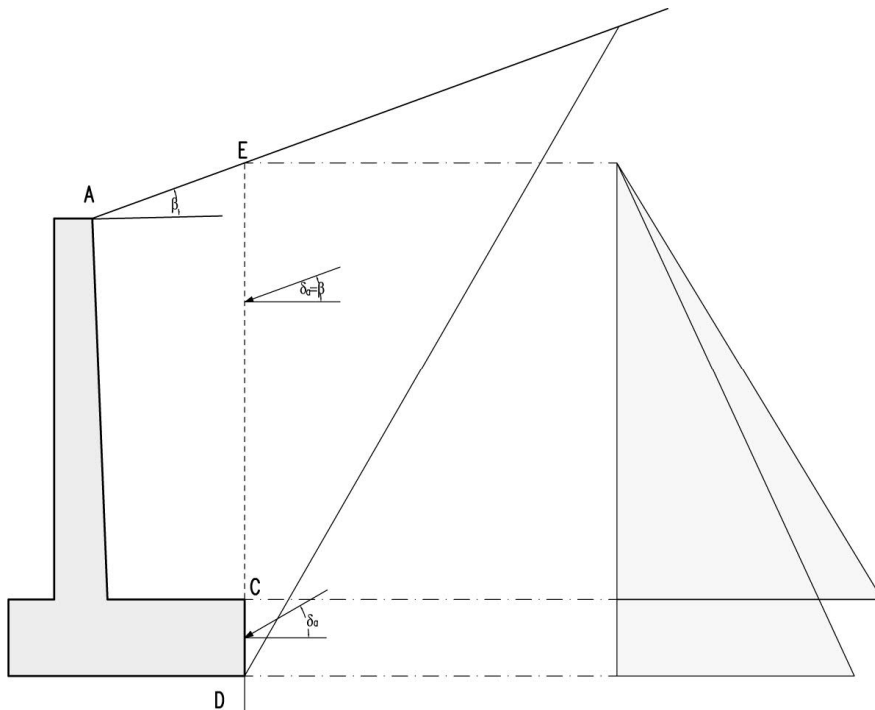

The earth pressure underneath the plane of rupture that acts on the heel is always calculated with the active earth pressure inclination angle of the angular retaining wall.

You can distinguish between earth pressure due to compaction, increased active earth pressure and earth pressure at rest in this connection.

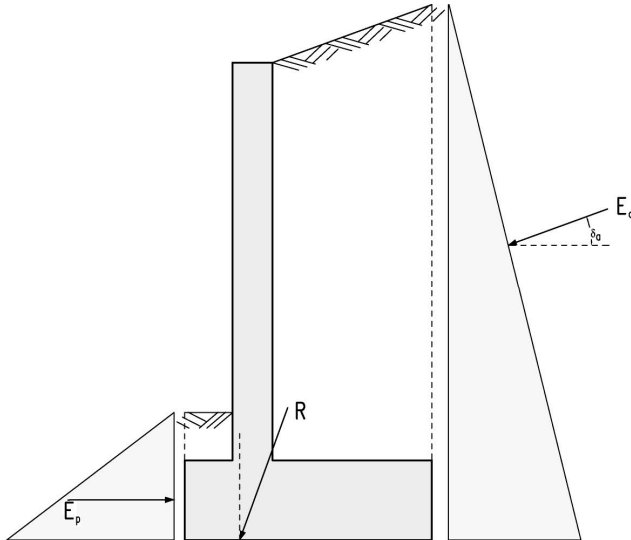

Earth pressure acting on the wall

The earth pressure on the wall only influences the design of the angular retaining wall (wall and foundation), not the geotechnical verifications.

It is assumed that the wall and the soil move together. Therefore, it is advisable to apply increased active earth pressure. Alternatively, you can apply earth pressure at rest, active earth pressure or earth pressure due to compaction. For the wall design, the actual earth pressure inclination angle is used. The earth pressure is calculated up to the bottom edge of the wall – see following figure.

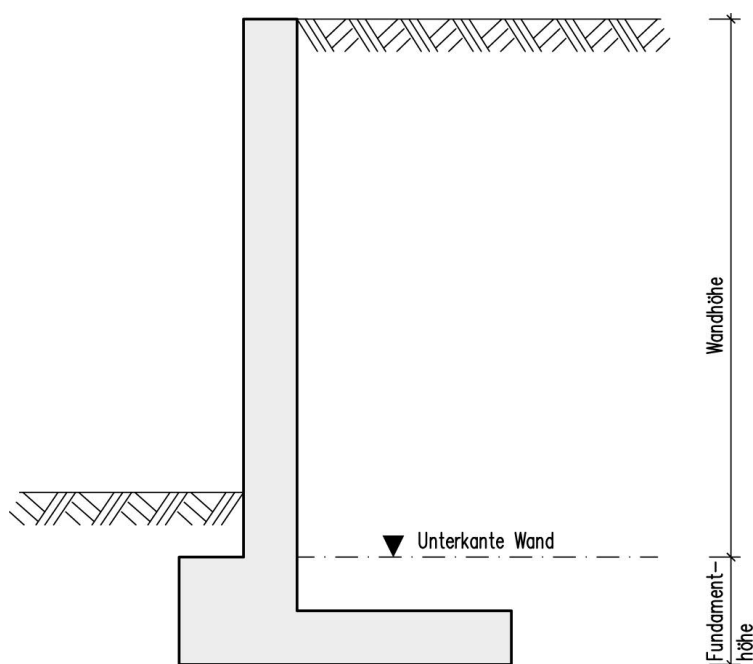

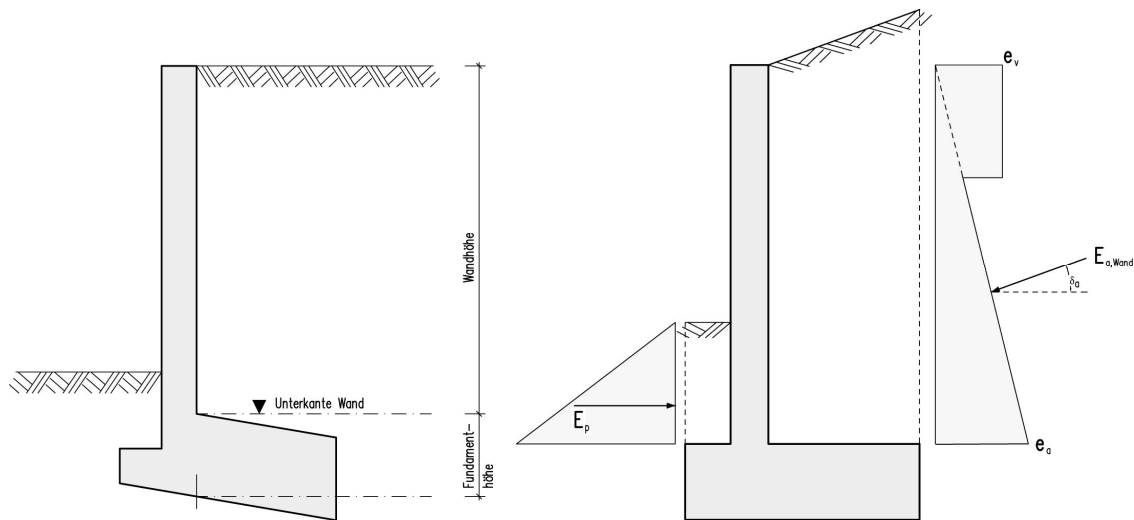

The earth pressure due to compaction that can be applied to the wall is independent of the earth pressure due to compaction that is applied to the joint of rupture because you can select the earth pressure application individually in both cases.

Earth resistance

Basically, you should consider earth resistance only if it will apply throughout the entire service life of the structure. Earth resistance is disabled in the software by default. If you activate the option, you can specify individually which percentage of the earth pressure should be considered in the respective verification. The software displays information about the values recommended in the standard.

If you select DIN EN 1997:2010 for calculation, the earth resistance can only be calculated with a purely horizontal inclination (i.e. the earth resistance has no vertical component), because DIN 1054 prescribes this approach for the ground failure analysis and recommends it for the sliding stability verification. Like the earth pressure, the earth resistance is calculated separately for the wall and for a vertical equivalent joint.

The same applies to the earth pressure: the earth resistance in the equivalent joint is used in the external stability verifications and in the foundation design; the earth resistance at the wall has only an influence on the wall and foundation design.

If the horizontal loads acting in the direction of the toe are higher than the applying earth resistance, the software automatically adjusts the application factors in such a manner that the earth resistance never exceeds the horizontal loads. In the ground failure analysis, it is made sure in addition that the applied soil reaction force is considered with maximally 50 % of the actual earth resistance if the verification is based on DIN EN 1997.

Other actions

Weight of soil

The weight of soil inside the sliding wedge is assumed to act on the heel of the angular retaining wall. On the toe, the weight of soil is automatically considered. If there is groundwater, the part of the soil that is under water is considered with its buoyant unit weight. The entire weight of soil is treated as a single action.

Water pressure

Water pressure is considered being hydrostatic. It is assumed that no flow or very low flow occurs and that the wall is embedded in soil with low permeability. The water pressure is applied all around the angular retaining wall height the corresponding height level and handled as a permanent action. The water pressure does not depend on the selection of the plane of rupture.

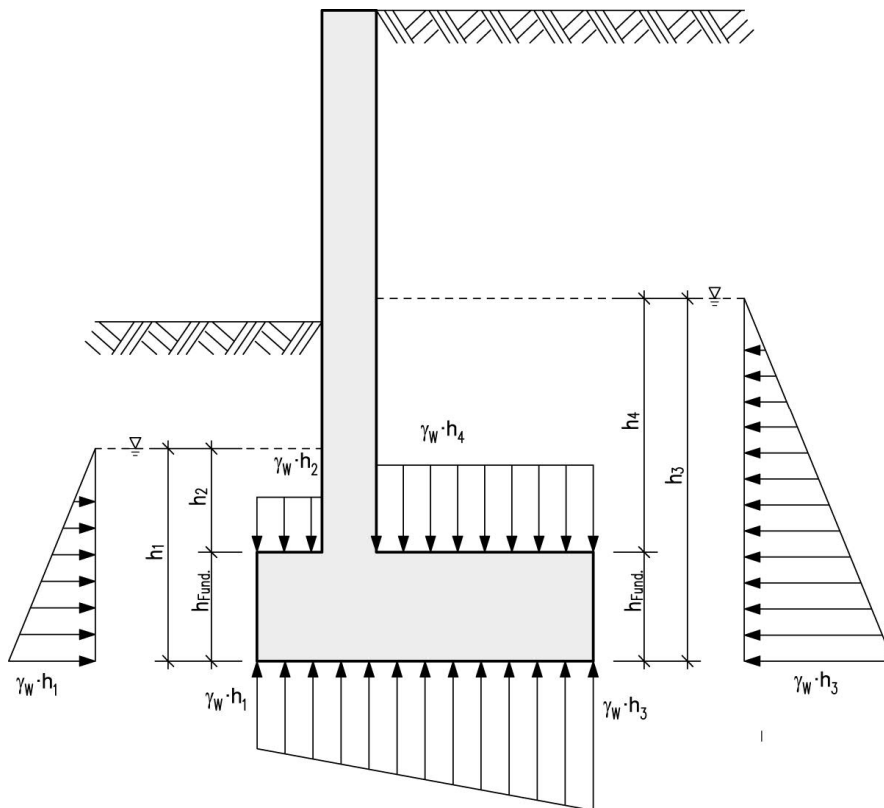

Ground-surface loads

Ground-surface loads generate earth pressure if they apply closely to the wall or to the plane of rupture. Loads that apply completely between the wall and the plane of rupture do not generate earth pressure on the plane of rupture but on the wall, however. Such loads always apply internally in the system and do not generate reaction forces if you consider the external system separately.

In the verifications, only the part of the resultant force is considered that applies inside the sliding wedge. This means that the resultant force of a ground-surface load can have no influence at all even if it starts at the wall head. This occurs exactly when the first plane of rupture hits the wall. In this case, the load generates earth pressure on the plane of rupture i.e. on the external system with a high vertical portion due to the inclination of the plane of rupture. If a load is extended until its influence reaches below the supporting wall, its effective proportion on the supporting wall decreases due to the geometry of the calculation approach.

Loads always apply in the way they are defined by the user. This means that loads are always considered fully, not only with their unfavourable portions, in all verifications with exception of the embankment failure analysis. Moreover, area loads below 10 kN/m^2 are not automatically treated as permanent loads independent of their actual group of action, as the EAB* allow it. The user can define the approach recommended by the EAB without any problems, however.

Earth pressure and the resultant force of a load are always considered together as a single action. Therefore, the vertical portion of load cannot act favourably and the horizontal portion of this load unfavourably, for instance.

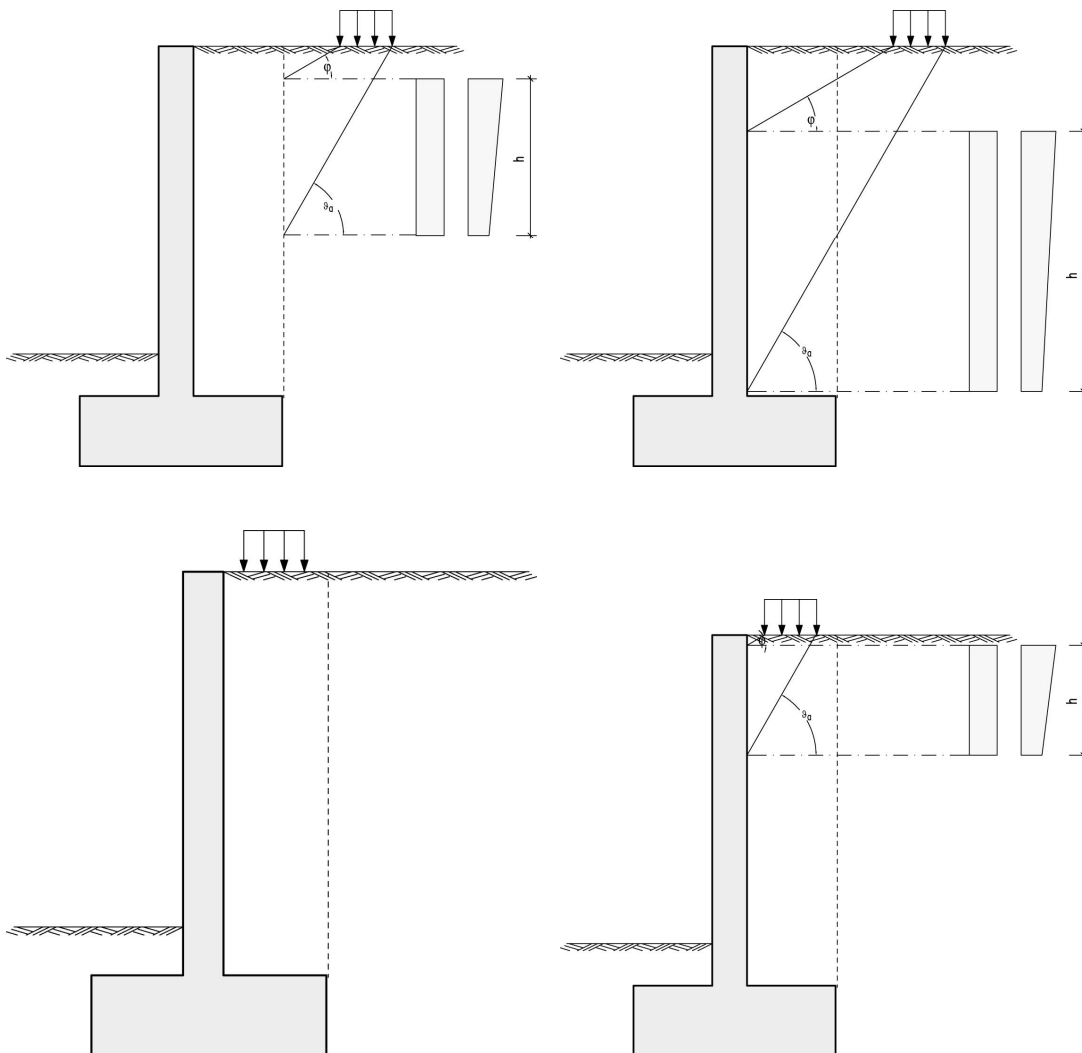

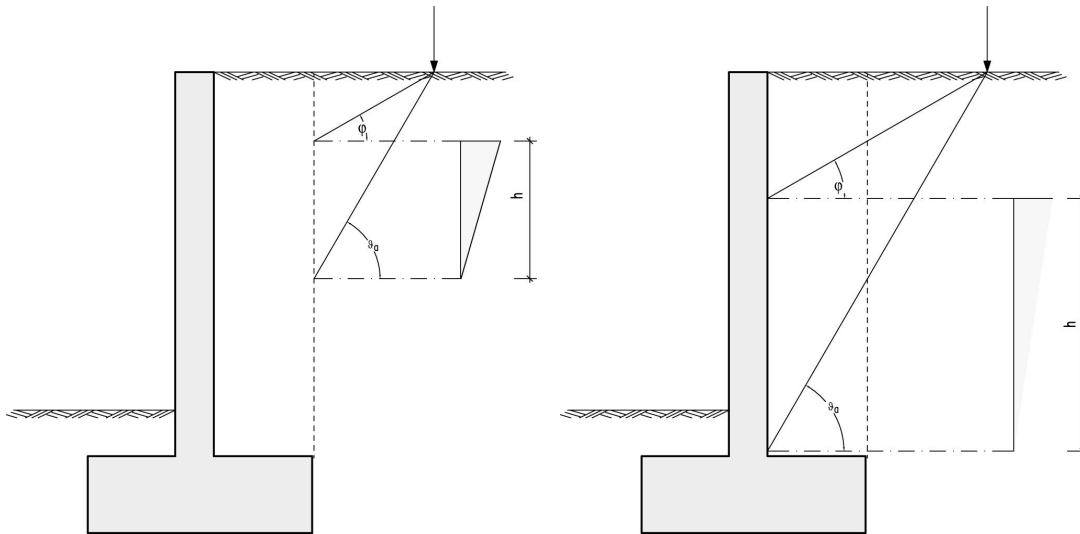

Component loads

Component loads do not generate earth pressure and are only included with their resultant force in the verifications of the external and internal stability.

Component loads can also act horizontally. Please note that horizontal loads in the heel-side direction (loads oriented to the right in WSM+) that exceed the total horizontal loads in the toe-side direction are not permissible. The software displays a corresponding error message in this case. Such a horizontal load would push the wall into the soil and contradict the assumptions the calculation is based on (such as overturning about the toe-side edge, ground failure mode in the toe direction and, finally, application of lateral earth pressure). If such a great horizontal load applies, you should consider lateral earth pressure in the verifications of the external stability in such way that you can map the low wall displacement due to the horizontal load (increase active, at rest).

Verification of the external stability

The verifications of the external stability are so-called geotechnical verifications or soil engineering verifications. With exception of the embankment failure analysis, earth pressure on the plane of rupture is considered in all verifications whereas earth pressure on the wall has no influence.

Overturning in accordance with DIN 1054

The verification of the overturning stability is based on DIN 1054 in the ultimate limit state involving a loss of overall equilibrium (EQU). In this verification, destabilising and stabilising design values of the moments about the toe-side edge of the retaining wall are compared.

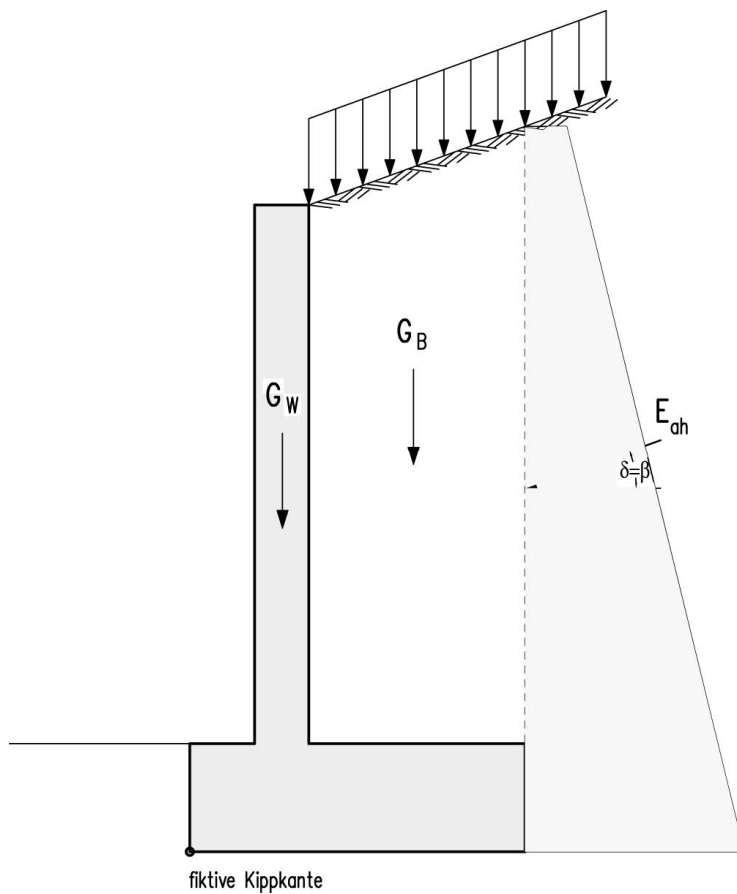

$$M_{G,k,dst} \cdot \gamma_{G,dst} + M_{Q,rep,dst} \cdot \gamma_{Q,dst} \leq M_{G,k,stab} \cdot \gamma_{G,stab}$$

Especially when earth pressure, whose vertical portion exceeds its horizontal portion, applies to the inclined plane of rupture, it may happen that no action has any destabilising effect because both earth pressure components are considered together.

Sliding

The sliding stability verification is performed in the GEO limit state (ultimate limit state involving the failure of structures, components and soil) in accordance with verification method 2 (GEO-2). In this limit state, the partial safety factors are the same for favourable and unfavourable permanent actions as per DIN 1054, i.e. permanent actions are not combined. If the verification is based on ÖNORM, the permanent actions are combined.

DIN 1054 specifies that the base friction angle δ_k required for the verification should not exceed 35° if it was not calculated specifically. For cast-in-place concrete foundations, it is set equal to the friction angle ϕ' of the soil layer in the base of the foundation (if the inclined base passes through several layers, averaging is based on the length). For foundations of pre-cast components, the base friction angle is set to maximally $2/3$ of the friction angle of the soil layer in the base. You cannot take adhesion into account.

The verification is as follows:

$$H_d \leq R_d + R_{p,d}$$

with:

$$R_d = \frac{V_k \cdot \tan \delta_k}{\gamma_{R,h}}$$

$$R_{p,d} = \frac{R_{p,k}}{\gamma_{Ep}}$$

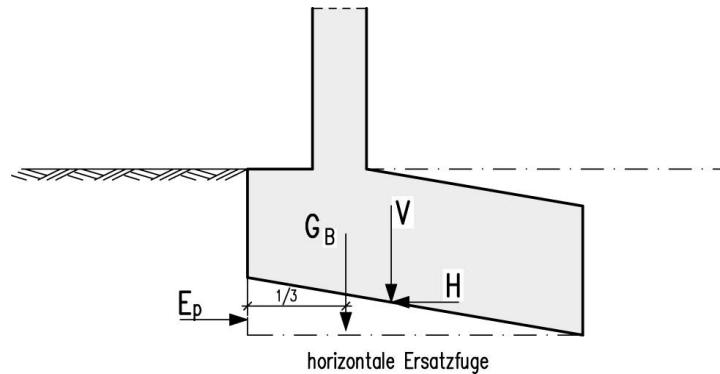

If the base area of the angular retaining wall is inclined, the verification must be performed in the base (with rotated loads) and, additionally, in a horizontal section (through the subsoil) underneath the base. In this verification, the loads are always rotated automatically to ensure that their direction of action is normal (N) and parallel (T) to the base. The more unfavourable verification becomes decisive. ÖNORM B4435-2 limits the base friction angle to $\phi/3$; compliance with this limit is checked by the software.

Because the loads are rotated, the horizontally acting earth resistance has a portion, which is perpendicular to the base. This portion is added to the vertical actions V_k in WSM+ and, consequently, influences R_d and not $R_{p,d}$. The portion normal to the base area is considered in the calculation of $R_{p,d}$.

In the verification of the section through the ground, the additional soil wedge and earth resistance in front of the soil wedge are considered by the software. The additional earth resistance is considered with the same factor as the earth resistance in front of the toe. If the earth resistance option is not checked, no additional earth resistance will be considered.

In this case, R_d is determined as follows:

$$R_d = \frac{V_k \cdot \tan \phi'_k + A' \cdot c'_k}{\gamma_{R,h}}$$

A' is the contact area of the equivalent shear joint.

Earth resistance can optionally be considered as additional resistance. If the earth resistance option is activated, you need to check additionally the displacement in the base area as per DIN 1054. If you include lateral earth pressure in the verification of the sliding stability as per DIN 1054, the software checks in addition whether the conditions to provide evidence of the stability against detrimental displacement of the foundations in the base area are satisfied in the limit state of serviceability. The verification is put out in WSM+. If the conditions are not satisfied, WSM+ cannot perform the required verification of the stability against detrimental displacement in the base area in the current version.

Ground failure

The detailed ground failure analysis is performed for a strip foundation in the GEO limit state, verification method 2. In this limit state, the partial safety factors are the same for favourable and unfavourable permanent actions as per DIN. If the verification is based on ÖNORM, permanent loads are combined with each other. For the effects of actions in the base area representative values are determined in accordance with EC7 which are included in the verification to calculate the ground failure resistance (via the eccentricity and the load inclination), see EC7, equation (2.7b) in 2.4.7.3. Earth resistance is considered as a soil reaction and included as an action. This soil reaction is included in the verification as per DIN with maximally half of the horizontal resultant force of the actual earth resistance.

If an embedment depth was defined for the angular retaining wall, the soil in front of the wall is regarded as stabilizing (no matter whether earth resistance is considered or not). A structural water load is not included as a stabilizing resistance that counteracts ground failure but only as an action, because water cannot transfer shear forces.

If the verification is performed in accordance with DIN, the vertical portion of the actions is compared to the vertical portion of the ground failure resistance. In combination with ÖNORM, the total actions are compared to the total resistance.

Simplified verification in typical cases (only with DIN)

The simplified verification in typical cases is performed as per DIN 1054 A 6.10. It replaces the verifications for the ULS 'ground failure' and 'sliding' as well as the verifications of serviceability.

If the simplified method should be used, some prerequisites must be met:

- a) The foundation base should be horizontal and the ground surface as well as the layer borders should be almost horizontal.
- b) The subsoil should have sufficient strength until below the foundation base, i.e. down to a depth twice as great as the foundation width; the minimum depth should be 2.0 m, see A 6.10.2.1 A(4) for non-cohesive soil or A 6.10.3.1 A (4) for cohesive soil.
- c) The foundation should not regularly or mainly be loaded dynamically.
No considerable excess pore pressure should occur in cohesive layers.
- d) A supporting effect of the soil in front of the foundation should only be considered if it is ensured by constructive or other measures that the soil remains in place.
- e) The inclination of the characteristic or representative resultant base pressure force should satisfy the condition:

$$\tan(\delta) = \frac{H_{\text{rep}}}{V_{\text{rep}}} \leq 0,2$$

- f) The conditions applying to the permissible eccentricity for characteristic and/or representative effects of actions as per 6.6.5 should be satisfied.
- g) The verification of the stability against loss of equilibrium through overturning as per 6.5.4 A (3) should be successful.

The prerequisites a), e) and f) are checked by the software. The user is warned in the event of non-compliance. The other conditions cannot be checked automatically, but they are included in the output so that the user can verify them.

After the verification of the criteria the calculation is performed. To ensure this, the design value of the base pressure effects of actions σ_{Ed} calculated by the software is compared to the design value of the base resistance σ_{Rd} entered by the user. The verification is successful if the following is true:

$$\sigma_{\text{Ed}} \leq \sigma_{\text{R,d}}$$

The design value of the base resistance can be taken either from a soil expertise or from expert literature. DIN 1054 gives tables for non-cohesive (paragraph A 6.10.2) and cohesive (paragraph A 6.10.3) soil for this purpose.

The simplified verification always produces more conservative results than the analytical verifications and is intended to help manual calculations in simple cases. We recommend performing analytical verifications as a rule.

The simplified verification in accordance with ÖNORM B4435-1 no longer complies with the state of the art. The standard has not been aligned to the new code concept in any way and therefore, we dispensed completely with his verification in WSM+.

Embankment failure

The embankment failure is a special case among the external stability verifications. Different load assumptions apply in this case. Embankment failure based on the method of slices as per Bishop is implemented with the partial safety concept as per DIN 4084 or ÖNORM EN 1997:2013. The verification is performed in the GEO ultimate limit state 3 (GEO-3). It is deemed successful if the following condition is true for the most unfavourable failure mechanism:

$$E_M \leq R_M$$

with:

$$E_M = r \cdot \sum_i \left((G_i + P_{vi}) \cdot \sin(\vartheta_i) \right) + \sum M_s$$

and

$$R_M = r \cdot \sum_i \frac{(G_i + P_{vi}) \cdot \tan(\varphi) + c_i \cdot b_i}{\cos \vartheta_i + \mu \cdot \tan \varphi_i \cdot \sin \vartheta_i} + \sum M_R$$

You can select an area that contains the centres of the slip circles that you want to examine. In addition, the radii of these circles are varied; the radii of slip circles, whose perimeters run through the angular retaining wall, are excluded. At the end of the calculation, the most unfavourable slip circle is put out. You can specify the number of slices.

As a rule, a higher number of slices and a higher number of circle centres and radii allow a more accurate calculation but increase the computing time. To find the most unfavourable failure mechanism, first select a larger area with a coarse grid of circle centres. Typically, the most unfavourable circle centre is situated above the wall on the left and the perimeter of this circle is tangent to the bottom edge of the foundation at the heel. If you have calculated the utilization for the coarse grid, perform additional calculations with finer grids at the points where the highest utilization occurred in the previous calculation. When you have found the most unfavourable circle increase the number of slices until the utilization remains unchanged. You should keep in mind that 'higher accuracy' in this context means higher calculation accuracy not more meaningful results. Because the model and the determination of the soil parameters involve a certain degree of uncertainty, higher calculation accuracy does not necessarily mean that you can predict more precisely the behaviour of the structural system.

If groundwater exists, the weight of the soil is adjusted automatically in this case as well. The influence of groundwater is considered with a hydrostatic approach, which delivers always inaccurate results on the safe side because the decay of the pressure potential in the penetrated soil is not considered. This assumption is justified and sufficiently accurate, because the angular retaining wall in the slip circle is not permeable. The resulting moment of the water pressure is added to $\sum M_s$.

Variable actions are only considered in the GEO-3 limit state if they have an unfavourable effect. WSM+ checks for each slice whether the portion of the load on the respective slice has a favourable or unfavourable effect. Therefore, the load is only applied to those slices where it has an unfavourable effect. Component loads are treated as external actions and are only considered in the calculation if they have an unfavourable effect and/or if they act permanently. Because they are treated as external actions ($\sum M_s$) they have, unlike the ground loads, no influence on the resistance of the slice.

DIN 4084 and ÖNORM B4433 forbid the calculation of slices whose inclination is greater than that of the earth resistance joint of rupture resulting at an angle of $\delta_p = 0^\circ$. In such cases, WSM+ includes the earth resistance that results at the last valid slice border with $\phi = \phi_d$, $c = c_d$, $\delta = \beta = 0^\circ$ instead of including the respective slices.

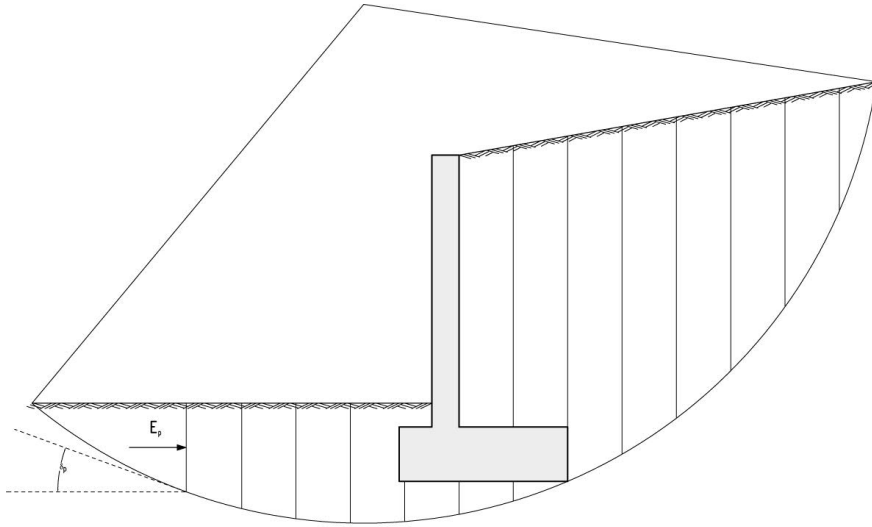

The slope is not considered in this connection because it is on the safe side if the last valid slice border runs within the slope. The soil layer thickness that is included for the earth resistance is always the difference between the height of the exit point and the depth of the joint of rupture at the last valid slice border.

The earth resistance is considered as a resistance moment in the equation by Bishop as follows:

$$\mu_{R,EP} = \mu \cdot E_p \cdot r_{E_p}$$

The action resulting from the soil weight in the slice is not considered.

Gaping joint/overturning as per ÖNORM B 4435-2

The verification of the limit of a gaping joint is performed in the serviceability limit state. It is based on EC7 and uses representative actions. The software checks whether the characteristic resultant base pressure force caused by permanent actions runs inside the first core range and whether the representative resultant soil pressure force of all actions (permanent and variable) runs inside the second core range. You can consider earth resistance also as an action and limit it with a factor.

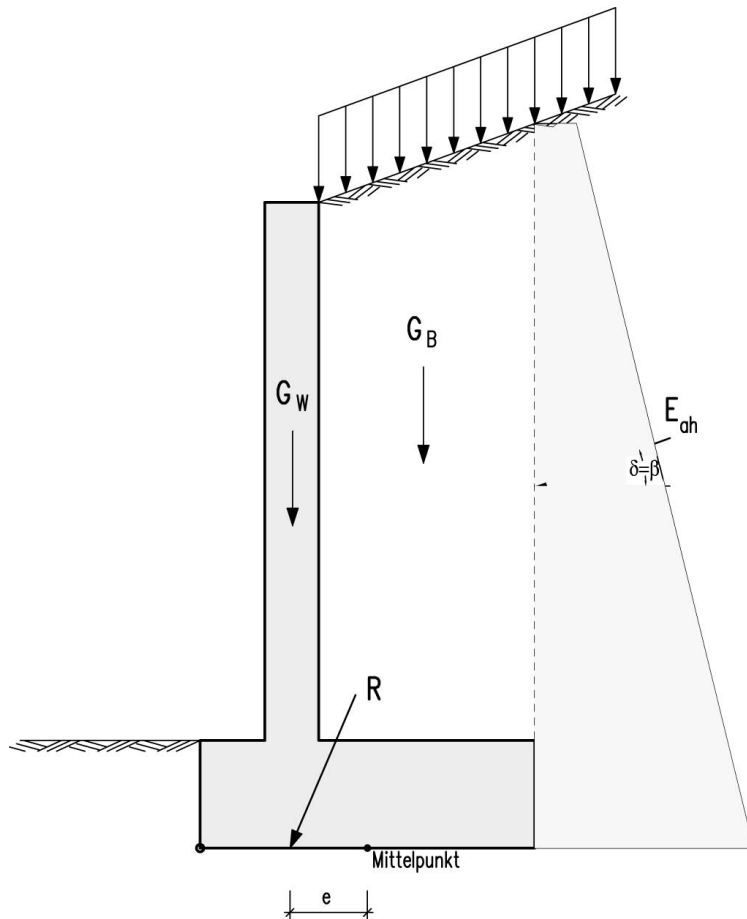

Settlement calculation

An indirect settlement calculation is performed according to the theoretical foundations in "Grundbau-Taschenbuch 1990", Volume 1 in the characteristic point of the foundation (foundation is assumed to be rigid). For this purpose, the program determines the stresses at short intervals within the soil layers and at layer boundaries and integrates them numerically. Both mean settlements and twists are calculated by the program.

In the settlement calculation, a preload that reduces the settlement-effective uniform soil normal stress can be considered. The preload can not be greater than the uniform soil load.

The limit depth to which the settlements are to be taken into account may either be specified or it shall be determined by the program as the depth at which the effective soil stress under the structure corresponds to 20% of the superposition stress.

The stiffness modulus, which is taken into account when determining the settlements, is the calculation module E^* according to DIN 4019. A possible correction coefficient must already be included in the calculation module so that it is taken into account.

$$E^* = \frac{E}{1 - \nu^2}$$

und

$$E_s = \frac{1 - \nu}{1 - \nu - 2\nu^2} \cdot E$$

Variable loads, as provided for in DIN 1054, can be taken into account via the approach of different combination coefficients.

Verification of the internal stability

In the internal stability analyses, the internal stability of the reinforced concrete component is verified. The bending design is performed in accordance with the kh (kd) method. Minimum reinforcement (including minimum compression reinforcement) is considered automatically unless you uncheck the corresponding options.

If the cross-section height varies, shear force is automatically increased or decreased in the verification of the load-bearing capacity, [when the respective option is checked](#).

Wall design

You can design the wall at a freely selectable number of points. It is loaded by lateral earth pressure (including earth pressure caused by loads), by its self-weight and, if applicable, by water pressure (including buoyancy) and component loads. For the calculation of the internal forces, the wall is idealized as a cantilever arm, the neutral axis of moments runs on the heel side (on the right) in this case.

Under normal conditions, a positive moment and a negative shear force result at the contact surface. Therefore, the bending reinforcement must be installed on the heel side.

A variable effective height reduces the value of the shear force in this case (the wall is always thicker on bottom than on top).

The software puts out the required reinforcement.

A buckling analysis is not performed. This verification can become decisive, however, when high vertical loads apply to the wall crown.

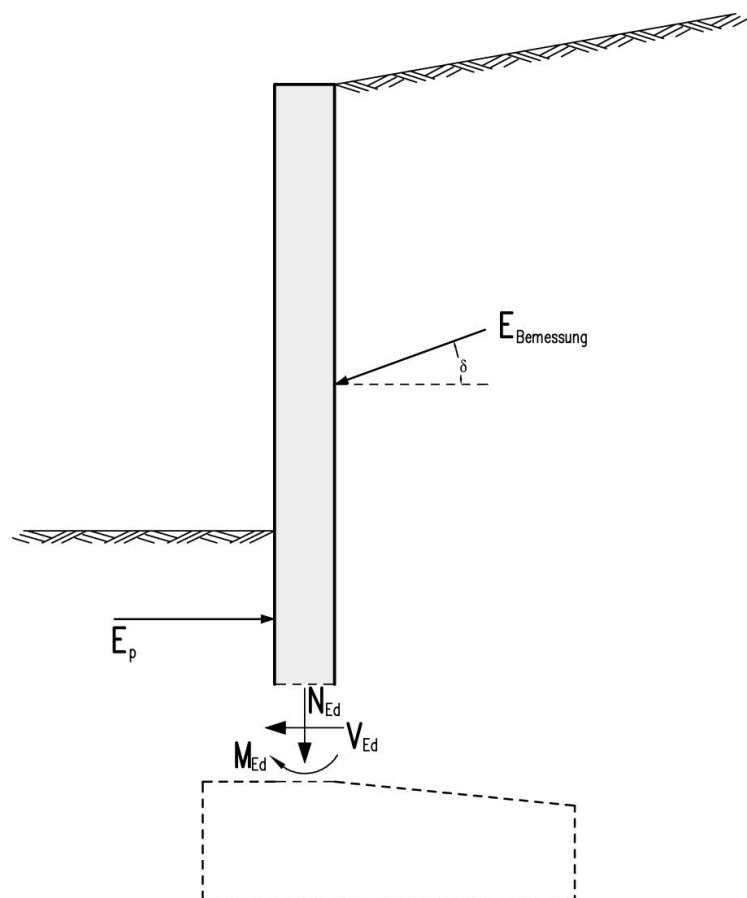

Foundation design

The foundation design is performed on the contact faces of the heel and the toe. Only the earth pressure on the contact faces (earth pressure of the internal stability) is known. Therefore, the heel and the toe can only be examined separately for the design in these points. Lateral earth pressure on the wall and earth pressure in the plane of rupture as well as self-weight, soil weight and, if applicable, water pressure (including buoyancy) act on the foundation. In addition to this, the design base pressure that results from the effects of actions on the external system is applied to the foundation. The horizontal component of the design earth pressure in accordance with /5/ is considered in the design to preserve the balance of forces.

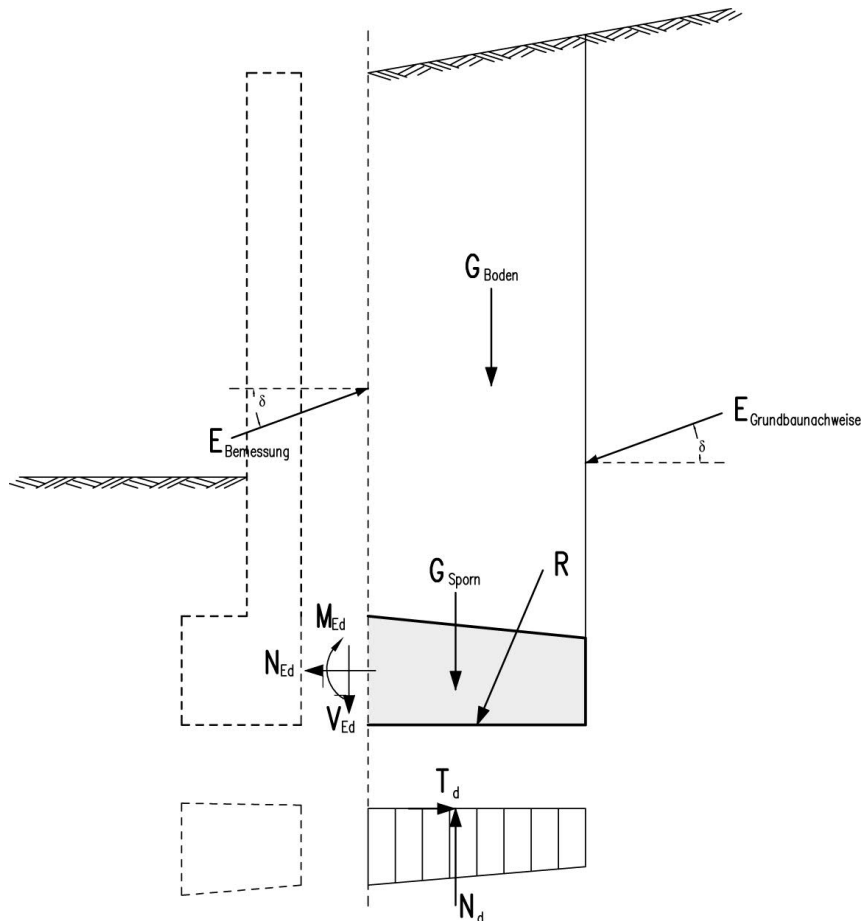

The design base pressure is calculated with the same combination of actions as the design at the respective point. Therefore, another base pressure pattern can become decisive for each of both sections and of both design situations (design for bending, design for shear force). Moreover, it may happen that the verification of the gapping joint in the ULS is successful, but the design base pressure cannot be calculated because a gapping joint exceeds the foundation edge in the design state. WSM+ displays an error message in this case.

The heel and the toe are idealized as cantilevers, the neutral axis of moments is on the bottom. Under normal conditions, the base pressure at the toe is high. Therefore, tension acts on the bottom side of the toe and the reinforcement must be installed there. In this case, an inclination of the base can help to reduce the applying shear force.

Due to the earth top load, the vertical load on the heel exceeds the vertical load caused by the base pressure under the heel under normal conditions. This situation causes tension on the heel top side. A haunch on the top side of the heel reduces the amount of shear force, an inclination of the base increases it.

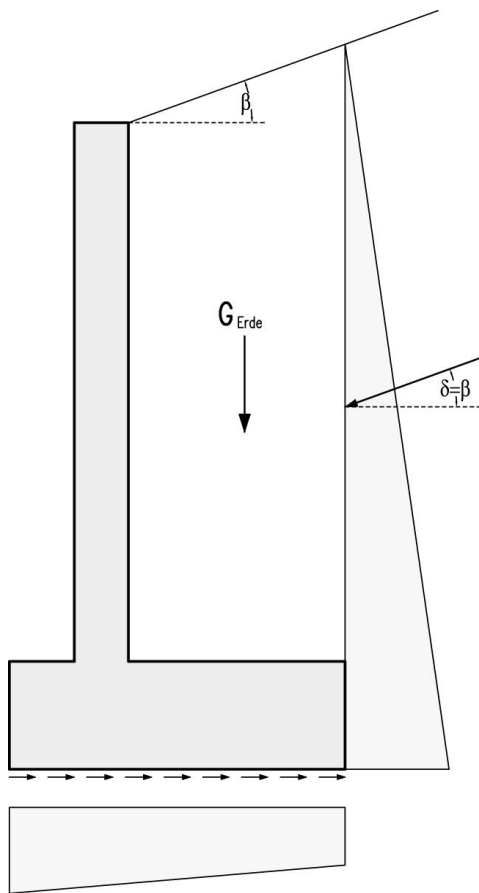

You can optionally display the required reinforcement schematically and put it out.

Data entry

You can enter values and define control parameters in the menu on the left screen section. The effect of the entered values is immediately shown in the graphical representation on the right screen section.

Before entering any data, you can edit the dimensional units (cm, m ...) via the options File ▶ [Program settings](#).

You should always define the system is such a way that the resistance face on the toe side is on the left and the action face on the heel side is on the right.

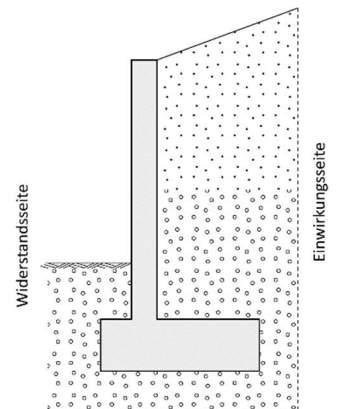

Wizard

The [wizard](#) is automatically launched when you start the software. You can disable the wizard in the settings menu.

In the wizard, the most important, basic item/system data are queried in compact form so that a calculable basic system is available. This can then be adapted in detail.

Input options in the graphical window

The data entry via the GUI is described in the document "[Basic operating instructions](#)"

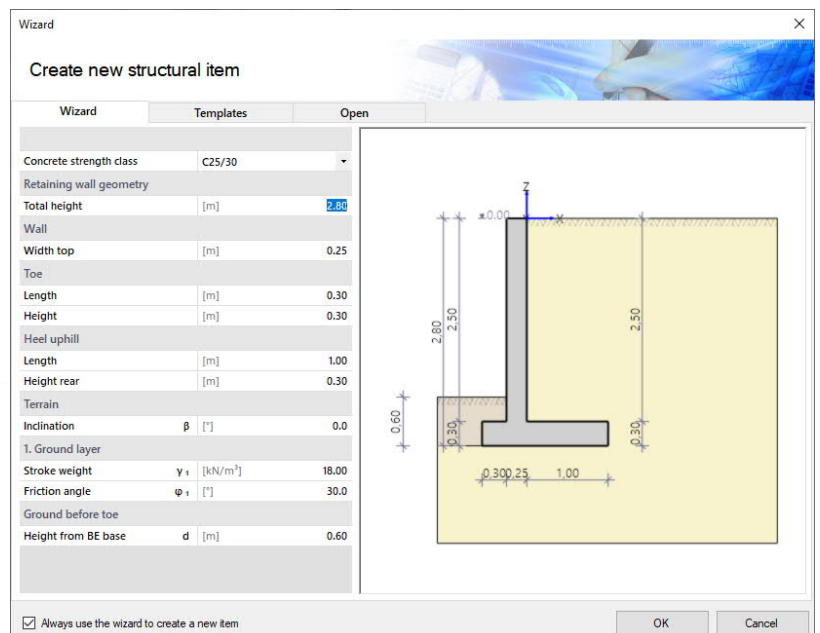

Basic parameters

Available standards

Select the desired reinforced concrete standard. The associated foundation engineering standard is set accordingly.

Comments

Click on the  button to enter your own [comments](#) on the system.

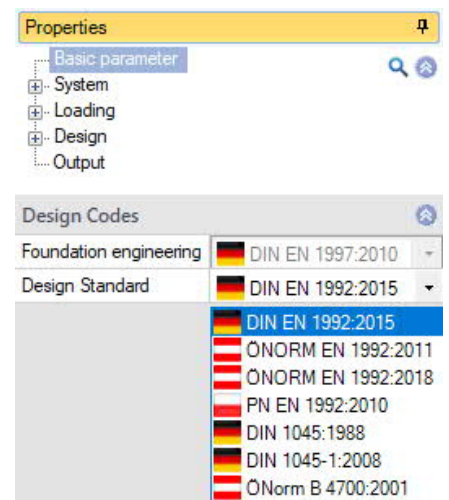

Structural system

Cantilevered retaining wall

Enter the dimensions of the wall, heel and toe, the base inclination and define additional parameters.

The data-entry fields are self-evident in most cases.

When you click into a data-entry field, additional text information is displayed in the information window below the menu on the left.

Base friction angle $\delta_{s,k}$

You can optionally include the base friction angle and set it equal to the friction angle of the soil layer underneath the base, if it was not determined in a separate calculation. The maximum value for this angle is 35°.

The base inclination angle of pre-cast parts should be set to $2/3 \varphi$.

Active wall friction angle δ_a

Friction angle between the wall and the soil for the calculation of the active earth pressure.

Passive wall friction angle δ_p

Friction angle between the wall and the soil for the calculation of the earth resistance. You must set this angle to zero for the detailed ground failure analysis as per DIN 4017.

Soil

Define parameters for the soil layers.

Parameters:

Unit weight, unit weight under buoyancy, friction angle, cohesion, calculation modulus E^* , thickness of the soil layer, height of the soil in front of the toe.

Explanations how to set the individual parameters are displayed in the information window.

Defining the layers

Enter the data of the first soil layer either in the corresponding data-entry mask or directly in the table, which you can display below the

graphic by activating the **Soil layers uphill** button .

Toolbar: 2/2

See [Data entry via tables](#) (Basic operating instructions)

To add soil layers, always set up a new entry first by activating the button (an empty data-entry mask is displayed each time).

The screenshot shows the 'Properties' menu on the left with options: Basic Parameters, System (expanded to show Cantilever wall, Soil, Terrain/Groundwater), Loads, Design, and Output. Below the menu is a table titled 'Retaining wall geometry' with the following data:

Retaining wall geometry		
Soil inclination	L-shape	
Soil inclination	[°]	5.0
Soil depths difference	[m]	0.22
Total height	[m]	2.80
Toe		
Length	[m]	0.30
Height	[m]	0.30
Heel uphill		
Length	[m]	2.00
Height rear	[m]	0.30
Haunch uphill side	[m]	0.00
Wall		
Stem length toe	[m]	2.50
Stem length heel	[m]	2.50
Width top	[m]	0.25
Haunch downhill side	[m]	0.00
Haunch uphill	[m]	0.00
Properties		
Concrete density	γ_b [kN/m ³]	25.0
Soil friction angle	$\delta_{s,k}$ [°]	30.0
Active angle of wall friction	δ	$2/3 \varphi$
Passive wall friction angle	δ_p	0φ

The soil friction angle, if it has not been determined separately for in-situ concrete foundations, is equal to the friction angle of the soil layer below the sole, but acc.to DIN maximum is at 35°. The soil friction angle for precast units should be set to $2/3 \varphi$.

Explanatory information about the currently active option

Ground surface / groundwater

Terrain

Ground begin Δz :

Distance of the top edge of the wall to the ground level (z-direction)

Slope:

None no inclination i.e. no sloped ground

Continuous the slope has a continuous inclination

Broken the slope can be divided into several sections with a different inclination each.

Inclination enter the inclination angle β of a continuous slope (negative value allowed)

An embankment/berm on the valley side can also be modeled. This influences the ground failure analysis and the calculation of the passive earth pressure.

Slope sections

If you have selected a discontinuous (broken) slope, you can define the individual sections and their inclination in this dialog (length, height, inclination).

Tabular input: see [Data-entry via tables](#) (Basic Operating Instructions)

Groundwater

If this option is checked, you can specify the toe-side and heel-side groundwater levels. Only negative values are allowed.

Terrain of the hill side ground			
Ground begin	Δz	[m]	0.00
Slope			broken
Slope segments 1/1			
Length	l_{xi}	[m]	1.00
Height	l_{zi}	[m]	0.18
Inclination	β	[°]	10.0
Inclination	1:		5.67
Terrain of the valley side embankment			
Slope			continuous
Inclination	β	[°]	-10.0
Terrain of the valley side soil			
Slope			without
Groundwater			without
Groundwater			continuous
Groundwater			broken
Groundwater level toe	hw1	[m]	0.00
Groundwater level, earth side	hwg	[m]	0.00

Loading

For input, click on the "Soil loads" or "Member loads" tab below the graphic - alternatively, you can use the [table input](#) (see Operating principles) in the left-hand menu.

Soil loads

- Load type area load, strip load, block load or line load
- Load value pi load value in kN/m² respectively kN/m
- Distance a distance to the inner edge of the wall top
- Width b width of a load applying perpendicular to the wall
- Length l length of a block load applying parallel to the wall
- depth of effect z distance of the load to the inner edge of the wall top in the z-direction. Values above the wall top edge are positive.
- Earth pressure distribution if limited live loads apply, you can select between a rectangular distribution and a trapezoidal distribution of the load as per EAB. The ordinates of the trapezoidal distribution result from a linear interpolation that depends on the distance to the wall and the width of the load.
- Action assignment of an action to this load
- Simultaneous group the loads of a simultaneous group always apply simultaneously.
A simultaneous group is defined by the number (0, 1, 2, ...) that is assigned to it.

Soil loads

Soil loads			1/1	+	-	X	+	-
load type		Block load						
Load value	pi	[kN/m ²]						0.00
distance	a	[m]						0.00
Length	l	[m]						0.00
Width	b	[m]						0.00
Depth of effect	z	[m]						0.00
Earth pressure distribution		trapezoid						
Action		Permanent loads						
Simultaneous group								0

Terrain loads on embankment on the valley side

Terrain loads on embankment on the valley side			1/1	+	-	X	+	-
load type		Area load						
Load value	pi	[kN/m ²]						0.00
distance	a	[m]						0.00
Action		Permanent loads						
Simultaneous group								0

Member loads

Member loads			1/1	+	-	X	+	-
Member		Coping						
load type		Area load						
Direction		vertical						
Load value beginning	pi	[kN/m ²]						0.00
Load value end	pj	[kN/m ²]						0.00
distance	a	[m]						0.00
Length	l	[m]						0.25
Action		Permanent loads						
Simultaneous group								0

Remarks

... about the actions

	load type	pi	a	l	b	z	Earth pressure distributi...	Action	Sim	Alt
			[m]	[m]	[m]	[m]				
→ 1	Area load	0.00	0.00	---	---	---	---	Permanent loads	0	0

Area load

Strip load

Block load

Line load

Terrain loads on valley-side embankment

To take into account stabilizing loads on the valley side.
Enter an area load pi, the distance to the angle retaining wall and the action.

Member loads

Tabular input: see [Data-entry via tables](#) (Basic Operating Instructions)

Member wall crown, toe, wall, front face of the toe

Load type area load, line load, moment load, depending on the component

Load value for an area load, the load values for the start and end of the load must be specified.

Distance/length the best way to understand the effect of this values and to see how it is measured is to enter a value and check the load position in the graphic.

Action and simultaneous group: see description of soil loads.

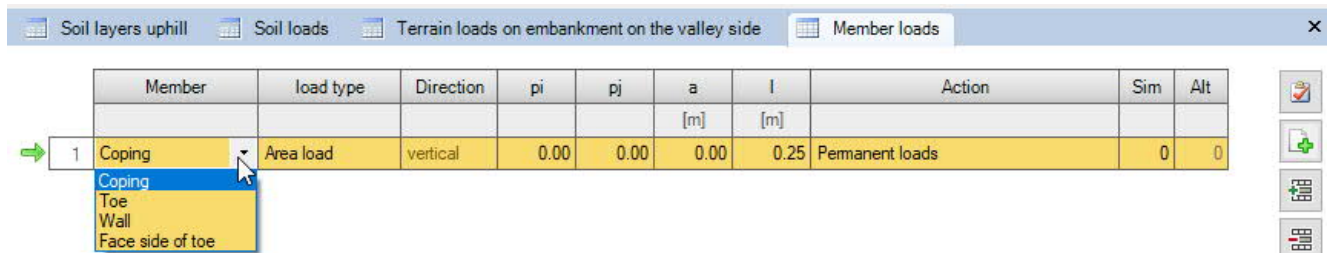

Member	load type	Direction	pi	pj	a	l	Action	Sim	Alt	
					[m]	[m]				
1	Copping	Area load	vertical	0.00	0.00	0.00	0.25	Permanent loads	0	0

Design

Lateral earth pressure

Earth pressure on for the geotechnical verifications, the earth pressure can be applied to the vertical section, the inclined sliding surface or the real rear edge of the wall. The application limits of these three different approaches are checked automatically and, if necessary, corresponding notes and warnings are generated.

Earth pressure type the earth pressure can be calculated either for the active earth pressure, the earth pressure at rest or an increased active earth pressure between these values.



Increased active earth pressure you must check this option if the movement of the wall is insufficient to trigger the limit state of the active earth pressure or to maintain it during the entire service life of the building. When you check the option, the corresponding data-entry field is displayed.

Apply tensile forces from cohesion calculated tensile stress caused by cohesion must not be considered with unbraced walls or walls with yielding bracing that rotate about their base point or a deeper point (EAB EB4 para. 3).
If the construction pit walls are fitted with low-yielding bracing and a redistribution of the earth pressure is expected, you may include calculated tensile stress caused by cohesion in the verification of whether minimum earth pressure is required (EAB EB4 para. 5). The software calculates the earth pressure for walls that rotate about their base point. Therefore, tensile stresses caused by cohesion should not be included under normal conditions.

Apply minimum earth pressure if the minimum earth pressure is considered (option ticked), the software checks for each layer of cohesive soil whether the earth pressure resulting from the self-weight of the soil and a shear strength that corresponds to the angle of inner friction $\phi = 40^\circ$ becomes decisive at a cohesion of $c = 0 \text{ kN/m}^2$. Calculation in accordance with EAB, 5th edition.

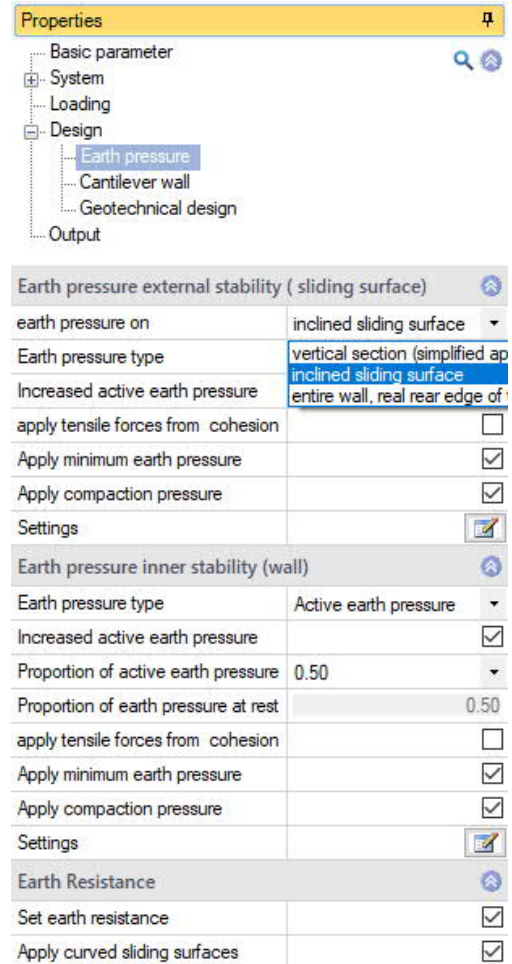
Apply compaction pressure... when soil is backfilled layer by layer and strongly compacted subsequently, the earth pressure exceeds the earth pressure resulting from the self-weight of the soil.



Earth pressure external stability (sliding surface)	
earth pressure on	inclined sliding surface
Earth pressure type	vertical section (simplified ap) inclined sliding surface
Increased active earth pressure	entire wall, real rear edge of
apply tensile forces from cohesion	<input type="checkbox"/>
Apply minimum earth pressure	<input checked="" type="checkbox"/>
Apply compaction pressure	<input checked="" type="checkbox"/>
Settings	
Earth pressure inner stability (wall)	
Earth pressure type	Active earth pressure
Increased active earth pressure	<input checked="" type="checkbox"/>
Proportion of active earth pressure	0.50
Proportion of earth pressure at rest	0.50
apply tensile forces from cohesion	<input type="checkbox"/>
Apply minimum earth pressure	<input checked="" type="checkbox"/>
Apply compaction pressure	<input checked="" type="checkbox"/>
Settings	
Earth Resistance	
Set earth resistance	<input checked="" type="checkbox"/>
Apply curved sliding surfaces	<input checked="" type="checkbox"/>

Settings

allows you to define additional parameters concerning compaction earth

pressure in a separate dialog (click on ):

Approach as per DIN 4085 or in accordance with 'Franke'

The compaction earth pressure for high compaction is calculated in accordance with DIN 4085. For light compaction (vibrating plate with an operating mass of up to 250 kg), the method described by Franke (Franke, D., Verdichtungserddruck bei leichter Verdichtung, BAUTECHNIK 85 (2008) Booklet 3, p. 197 to 198) should be selected.

Curved planes of rupture:

The depth 'zp', at which the full compaction earth pressure is considered, is determined by comparing the compaction earth pressure to the passive earth pressure. The associated passive earth pressure coefficient can be determined in combination with linear and curved plane of ruptures.

The compaction width and the resilience of the wall are displayed - please observe the tool tips.

ÖNorm B4434: Compaction force. It corresponds to the load per length unit of the roller lining for static compactors. For vibrating rollers, it is composed of the weight and the centrifugal force. If the centrifugal force is not known, you can apply the compaction force approximatively with twice the weight per length unit.

Set earth resistance:

You should only apply earth resistance if it is ensured that the earth in front of the toe will not be removed during the entire service life of the angular retaining wall. You must define in another dialog whether earth pressure is included fully or with a reduction factor

(▶ Design ▶ Cantilever wall ▶ Reduction factor, Soil engineering verifications, see below).

(▶ Design ▶ Geotechnical design ▶ [Earth Resistance](#)

Apply curved sliding surfaces:

the assumption of linear planes of rupture for the passive earth pressure is inappropriate under the following conditions: $|\alpha + \delta| < \beta$ and $\varphi > 35^\circ$. The earth pressure coefficients for curved planes of rupture are determined in accordance with DIN 4085 Annex C. The representation is always linear.

Cantilever wall

Reduction factor the factor can range between 0.0 and 1.0. The greatest value means that the full earth pressure resistance is considered in the design of the wall and the foundation. (This option is only available if the option 'Set earth resistance' was checked).

Design of the wall

Number of wall sections the number you specify for 'n' indicates the number of points at which you wish to determine the internal forces and to design the wall. The sections all have the same distance to each other. If you set $n = 1$, the design is only performed at the intersection of the wall and the foundation.

Durability see the document ["Durability - Creep Coefficient.."](#)

Concrete select the concrete quality and the reinforcing steel grade.

Reinforcement layer distance of the reinforcement layer (to the heel-side face/ to the toe-side face)

Min. ductility reinforcement when you activate this option, the software checks whether the required reinforcement falls below the minimum ductility reinforcement. The minimum ductility reinforcement will become decisive in this case.

Min. compressive reinforcement allows you to consider a minimum compressive reinforcement in the bending design.

Min transversal reinforcement If this option is activated, the software checks whether the required reinforcement is below the minimum transversal reinforcement. The minimum transversal reinforcement will be decisive in this case.

Design of the foundation

As the wall check this option when the parameters for the wall are the same as for the foundation. You need not enter the values again in this case.

Shear force analysis / Vaults

if the effective height varies, shear force is increased automatically, and you can decide whether a reduction should be applied. The increase is always considered automatically irrespective of your selection.

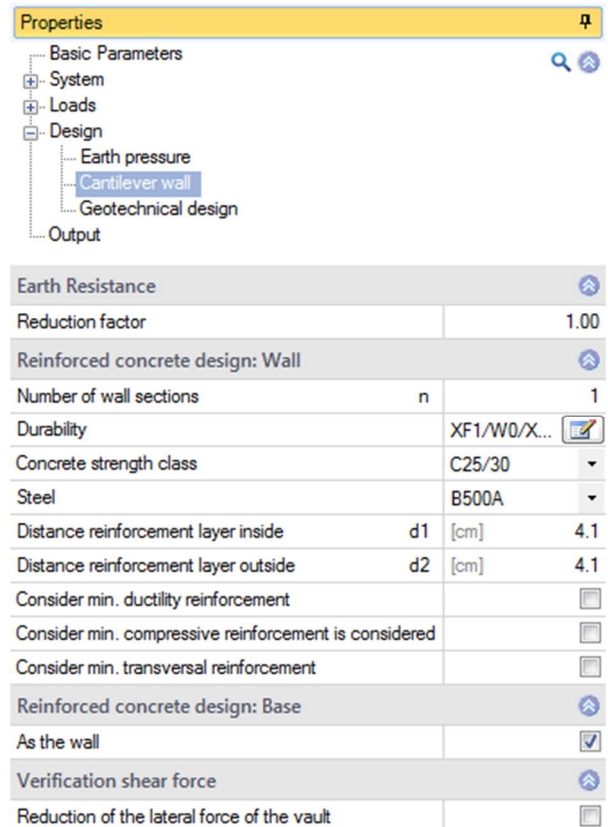

Geotechnical design

Earth resistance

With active option [earth pressure](#) – set earth resistance.

Factor base failure proof:

You may include earth resistance as per DIN 1054 with a maximum factor of 0.5. It is considered as an action.

Factor toppling resistance:

The resultant force of the earth resistance can be multiplied with a factor ranging from 0.0 to 1.0, which reduces the actual value. The factor used for the overturning stability verification applies also to the simplified verification in typical cases and to the verification of the limitation of the gaping joint.

Factor sliding proof:

The resultant force of the earth resistance can be multiplied with a factor ranging from 0.0 to 1.0 to be considered in the verification. You may only consider earth resistance in the sliding stability verification if it is ensured that the soil will remain in front of the toe throughout the entire service life of the retaining wall. Moreover, you may only include the entire earth resistance (factor = 1.0) if it is ensured that the wall displaces sufficiently to mobilize the passive earth pressure. If you include earth resistance with the factor 0.5, it is expected that the corresponding earth pressure and the base friction are activated approximately at the same time.

Base failure - Type of proof

You can perform the ground failure analysis either

- as an [calculated verification](#) (DIN 1054 6.5.2.2 or DIN 4017 / ÖNorm B 4435-2) or
- when using DIN EN 1997 as a [simplified verification](#) (DIN 1054 6.10) based on specified permissible base resistances σ_{Rd} , it replaces the ground failure analysis, the sliding stability verification and the settlement analyses.

Soil properties

Note: This option is only available if base failure - type of proof "simplified" has been selected.

Determination $\sigma_{R,d}$ You can choose whether the design value of the base pressure resistance should be specified directly or should come from a self-specified table.

From own table Use the "edit" button to call up the table dialog (fig. right). Here you can enter or select your own values for the base pressure resistance, anchoring/embedment depth and foundation width.

Earth Resistance	
Factor base failure proof	0.50
Factor toppling resistance	0.50
Factor sliding proof	0.50
base failure	
Type of proof	calculated
Slope stability	
Calculate slope stability	<input checked="" type="checkbox"/>
Slope stability dialog	
Sliding	
Perform sliding check	<input checked="" type="checkbox"/>
Settlement	
Settlement limit depth	Calculate
Excavation discharge	σ_v [kN/m ²] 0.00
Length of cantilever retaining wall	ly [m] 20.00
Consideration of permanent loads	not considered

Bearing pressure resistance	Anchoring depth	b
[kN/m ²]	[m]	[m]
100.00	0.00	0.00
200.00	0.00	3.50
200.00	2.00	0.00
300.00	2.00	3.50

Design value of the base pressure resistance for the permanent design situation BS-P. This design value results from the characteristic base pressure resistance divided by the safety

Slope stability



The slope stability verification must always be carried out. With complex systems, however, the calculation takes a very long time, which is why it is possible to switch off the verification for the time during input.

Slope stability dialog:

Note: This option is only available with licensed program BBR - Slope Failure Analysis!

Use this button  to open the dialog.

min. X/Z-value	X or Z coordinate of the lower left point of the grid of the center points of the slide circle.
Width/Height raster	Width/Height in X/Z-direction of the grid der of the center points of the slide circle.
Select searching area	Click on the  button to select the search area for the center of the slide circle interactively with the mouse in the graphic.
Number of raster points	Number of points in the x or z-direction where the center of the sliding circle should be located. The centers are evenly distributed.
Number of radii	Number of radii to be examined. The radii are evenly distributed between the minimum and maximum radius. The minimum radius results from the condition that the sliding circle does not intersect the cantilever wall The maximum radius results from the depth of the entered soil layers.
Maximal depth	Depth from the lower edge of the heel-side foundation edge (measured positively), up to which slide circles are to be checked. This setting automatically controls the maximum width of the terrain to be examined. If the specified soil layers do not reach the specified depth, the lowest soil layer is internally assumed for the calculation up to the specified depth.
Number of lamellae	The finer the slat division, the more accurate the result. Normally, a fineness of 20 slats is sufficient. The number of lamellae actually used also depends on constraints, e.g. Layer boundaries or load application points, and therefore does not exactly match the value given here.

Slope stability		
Slope stability 		
min. X-value of the raster	[m]	-2.50
min. Z-value of the raster	[m]	0.00
Width of raster	[m]	2.50
Height of the raster	[m]	1.10
Select searching area		
Number of raster points in X		6
Number of raster points in Z		6
Number of radii		5
Maximal depth	[m]	5.00
Number of lamellae		20

Sliding

Perform sliding check Here you can specify whether a sliding check should be performed.

Settlement

Settlement limit depth	Defines the type of determination of the settlement limit depth. The limit depth is the depth up to which settlements are to be calculated from the surcharge. This depth can either be calculated by the program using the 20% criterion or entered manually.
Excavation discharge	If soil is removed before loading, only the part of the load exceeding the excavation discharge will be effective.
Length of cantilever retaining wall	For the settlement calculation, a length of the cantilever retaining wall in the y-direction is required. This length only affects the settlement calculation and is otherwise ignored.
Consideration of permanent loads	It is only necessary to take account of the statutory proportion of permanent loads. Select whether the non-permanent loads should be taken into account in the settlement calculation and, if so, with which combination coefficient.

Results

The 'Results' tab allows you to display various result graphs.

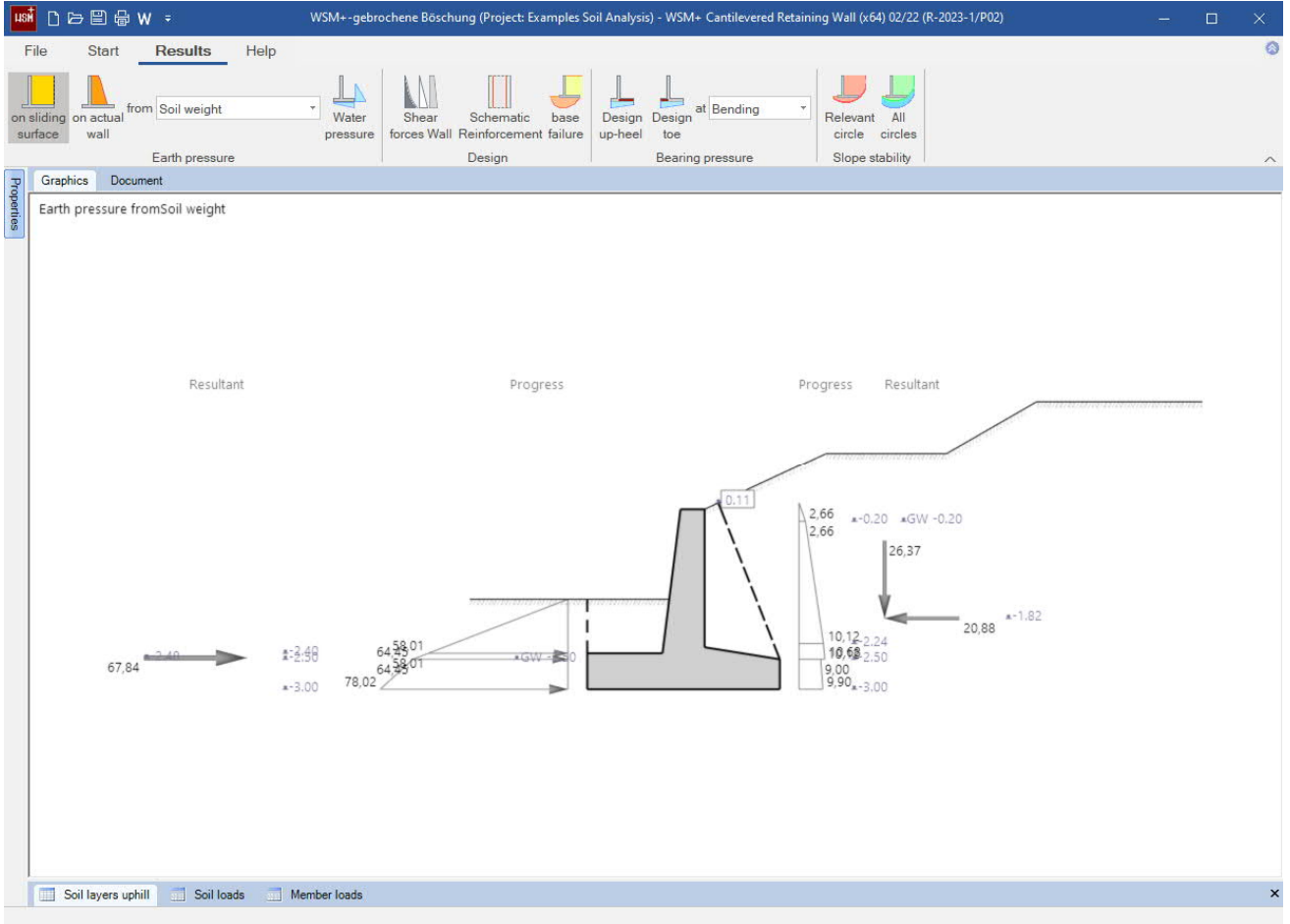

Fig.: Results - earth pressure - 'at plane of rupture'

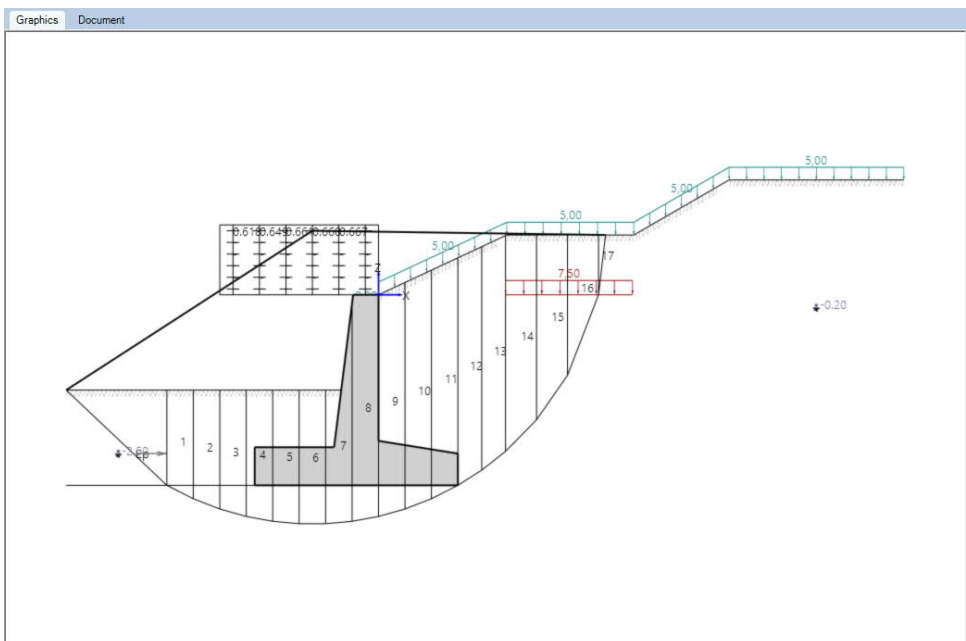

Fig.: Results - ground failure - relevant circle

Symbols for the result graphs



Lateral earth pressure

At plane of rupture earth pressure for the verification of the external stability (geotechnical verifications)

At actual wall earth pressure for the verification of the external stability (wall design)

Earth pressure caused by

- Weight of soil
- Cohesion
- Compaction
- Self-weight and cohesion
- Earth pressure and compaction
- Loads

Water pressure

Design

Internal forces in the wall characteristic internal forces

Schematic reinforcement drawing

Base failure

Base pressure for

Design of the heel

Design of the toe

with respect to

- Bending
- Shear force

Slope stability

Relevant circle decisive slip circles

All circles all examined slip circles are displayed.

Output

Scope of the output and options

In addition to the default settings “Brief” and “Detailed”, you can customize the scope of data to be put out by checking or unchecking the corresponding options.

General	
Output scope	detailed
Detailed calculation of effects	<input checked="" type="checkbox"/>
Maximize graphics	<input type="checkbox"/>
Details durability:	<input checked="" type="checkbox"/>
Geotechnical verifications	
Detailed geotechnical verifications	<input checked="" type="checkbox"/>
Show earth pressure calculation	<input checked="" type="checkbox"/>
Show earth pressure graphics	<input checked="" type="checkbox"/>
Show water pressure calculation	<input checked="" type="checkbox"/>
Show the calculation of base failure capacity	<input checked="" type="checkbox"/>
Detailed bearing resistance check	<input checked="" type="checkbox"/>
Reinforced concrete analysis	
Detailed RC verifications	<input checked="" type="checkbox"/>
Show earth pressure calculation	<input checked="" type="checkbox"/>
Show earth pressure graphics	<input checked="" type="checkbox"/>
Show graphic of wall shear forces	<input checked="" type="checkbox"/>
Show bearing pressure calculation	<input checked="" type="checkbox"/>
Show soil pressure graphics	<input checked="" type="checkbox"/>

Output as a PDF file

On the ‘Document’ tab, a PDF document is displayed.

See also the document [Output and printing](#).

The screenshot shows the 'Document' tab in the software interface. The main content area displays a PDF document with the following sections:

Frilo Software
 Stuttgarter Str. 40 | Tel.: +49 711 810020 | Projekt: GGUTest
 70469 Stuttgart | Fax: +49 711 858020 | Position: 4. inclined GF
 19.09.2017 | Seite: 3

Required reinforcement

Location	Flexural reinforcement		Shear reinforcement a _{sw, req} [cm ² /m]	Superposition
	a _{s, req, top/outer} [cm ² /m]	a _{s, req, bottom/inner} [cm ² /m]		
Constrained wall	1.88	2.84		5
Cut part heel	3.52	0.00	0.00	5
Cut part toe	2.25	3.30	0.00	6

Overview of superposition and load cases

Actions

Name	ψ ₀	ψ ₁	ψ ₂
Permanent loads	1.00	1.00	1.00

Load cases

No.	Name	Action
1	Soil and wall weight	Permanent loads
2	Earth pressure from dead load	Permanent loads

Decisive combinations (permanent design situation)

No.	Limit state	decisive combination
1	EQU	0.90×(1) + 0.90×(2)
2	STR/GEO-2	1.35×(1) + 1.35×(2)
3	GEO-3	1.00×(1)
4	SLS	1.00×(1) + 1.00×(2)
5	STR/GEO-2	1.00×(1) + 1.35×(2)
6	STR/GEO-2	1.00×(2) + 1.35×(1)

The load numbers are in brackets

Geotechnical verifications

Earth pressure

Active earth pressure factors

from z = [m]	to z = [m]	α [°]	φ' [°]	δ [°]	θ _{a, max} [°]	k _{eph} [-]	k _{ech} [-]	k _{eph} [-]
0.09	-2.50	26.6	30.0	30.0	60.0	0.407 ²	0.519 ¹	0.374 ⁴
0.09	-2.50	26.6	30.0	30.0	60.0	0.332 ²	0.478 ²	0.332 ²

Reference literature

- /1/ Jenne, G.: "Erddruck". In: *Beton-Kalender II*, 1973, p. 89.
- /2/ Simmer, K. und Schulze, W.E.: *Grundbau Teil 1. Bodenmechanik und erdstatische Berechnungen*. (B. G. Teubner) Stuttgart 1974.
- /3/ Funke, L.: "Erddruck auf Stützbauwerke infolge Straßenverkehrslasten nach DIN 1072", in: *Bauingenieur* 58, 1983, p. 349.
- /4/ Hoesch Stahl AG (Publisher): *Spundwand-Handbuch Berechnung*. Dortmund 1986.
- /5/ Mesterom, K.-L.: "Beitrag zur Bemessung des erdseitigen Spornes von Winkelstützmauern", in: *Bautechnik* 7, 1985, p. 235 to 237.
- /6/ Henner Türke.: "Statik im Erdbau" Ernst & Sohn, 3rd edition
- /7/ DIN EN 1997-1 [2010-12] NA
- /8/ DIN 1054 [2010-12]
- /9/ DIN 4017 [2006-03]
- /10/ DIN 4019 [2015-05]
- /11/ DIN 4084 [2009-01]
- /12/ DIN 4085 [2011-05]
- /13/ DIN EN 1992-1-1 [2011-01]
- /14/ DIN 1045-1 [2008]